

Robótica Educativa WeDo



DOCENTES FORMADORES:

- ❖ Sonia Rojas Dalguerri
- ❖ Juan Carlos Barreto Cisneros



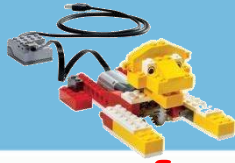

WeDo



MÁQUINAS SIMPLES

RUEDAS Y EJES

PALANCAS

POLEAS

ENGRANAJES



PALANCAS

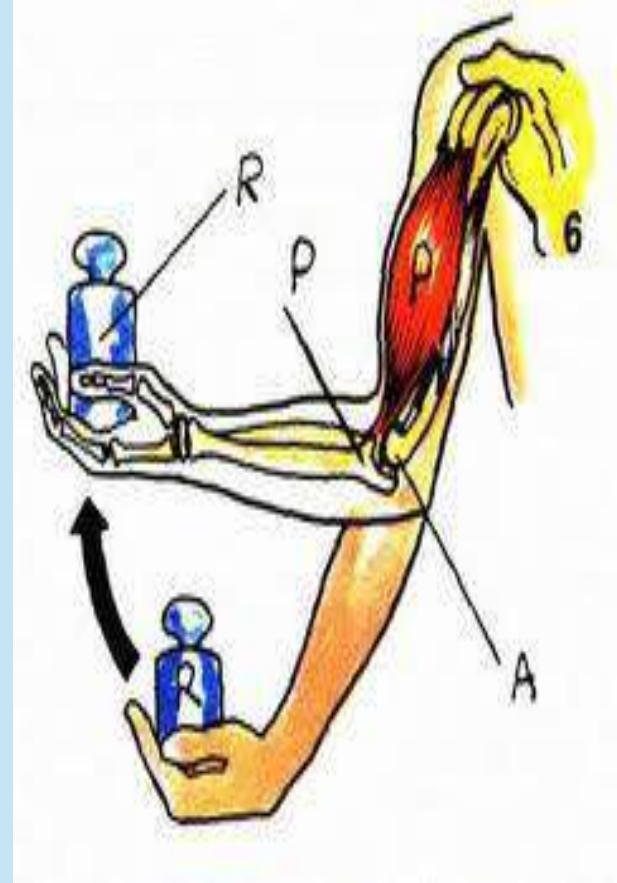

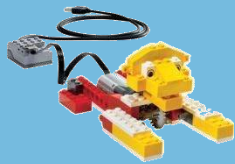

WeDo



PALANCA

La palanca es una máquina simple que transmite la fuerza que se aplica en un punto a otro punto en el que se obtiene una fuerza mayor.



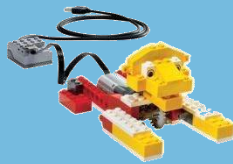

WeDo



PRIMER TIPO

En las palancas **de primer género** el punto de apoyo está entre el peso y el lugar de aplicación de la fuerza.

(La piedra pequeña que actúa como apoyo está entre la roca grande y la fuerza del grupo de personas.)



SEGUNDO TIPO

En las palancas **de segundo género** el peso se encuentra entre el apoyo y el lugar en el que hacemos la fuerza.

(El peso que lleva la carretilla está entre la rueda que actúa como apoyo y la fuerza que hace el obrero.)

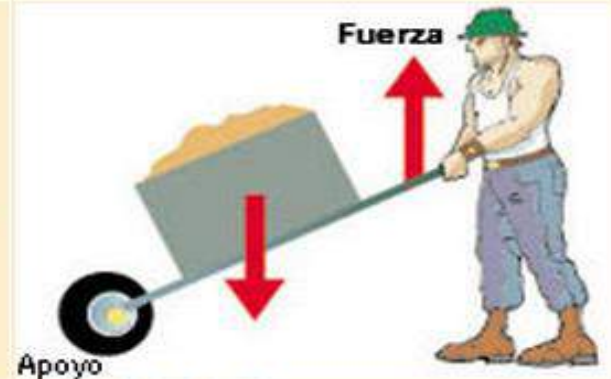

TERCER TIPO

En las palancas **de tercer género** la fuerza se aplica entre el punto de apoyo y el peso.

(La fuerza la realiza el brazo izquierdo del pescador. Esta fuerza se aplica entre el apoyo del brazo derecho y el peso del pez.)



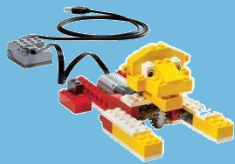

WeDo

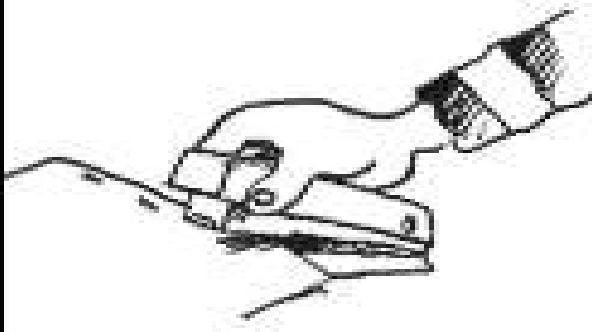
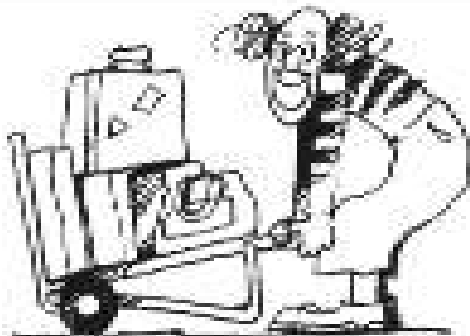

Palanca de primera clase



Palanca de segunda clase



Palanca de tercera clase

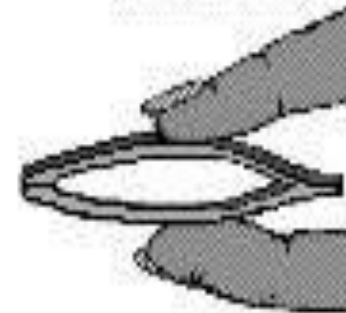

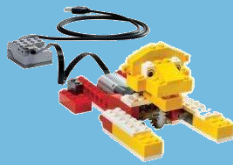

WeDo

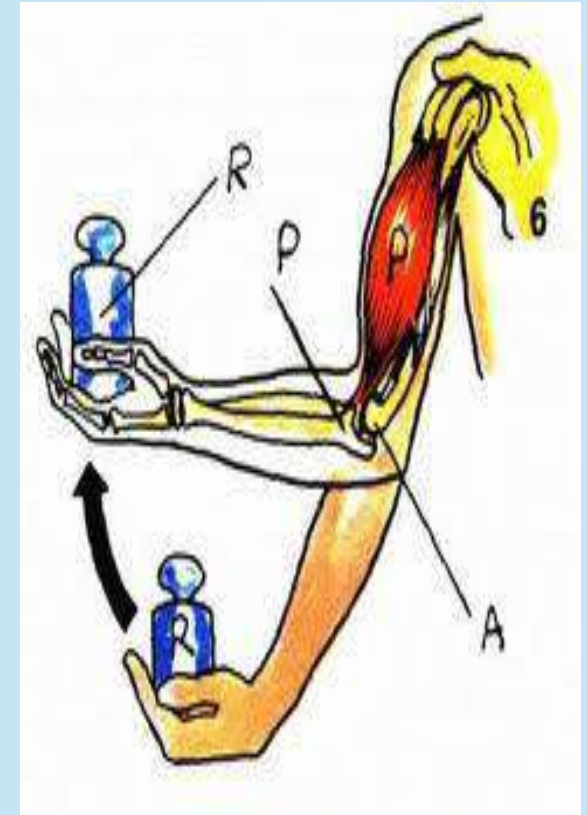
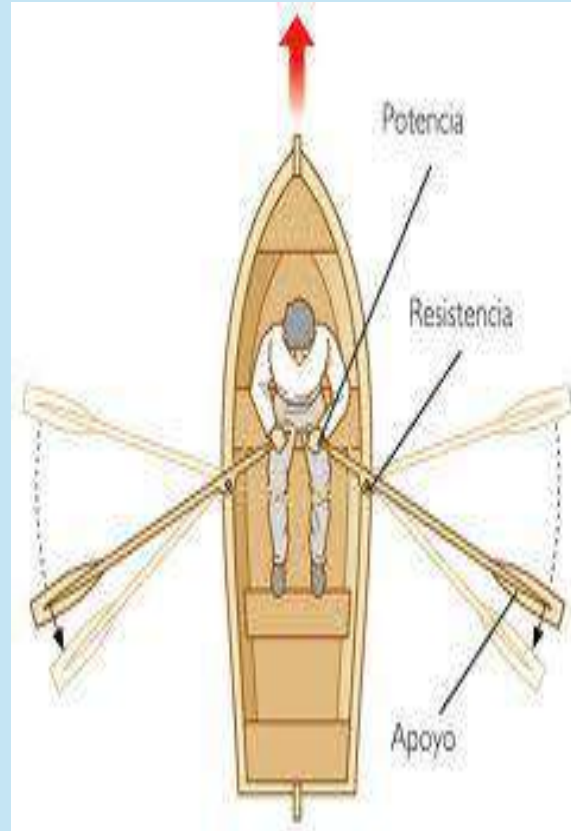

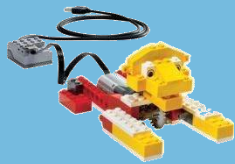

WeDo

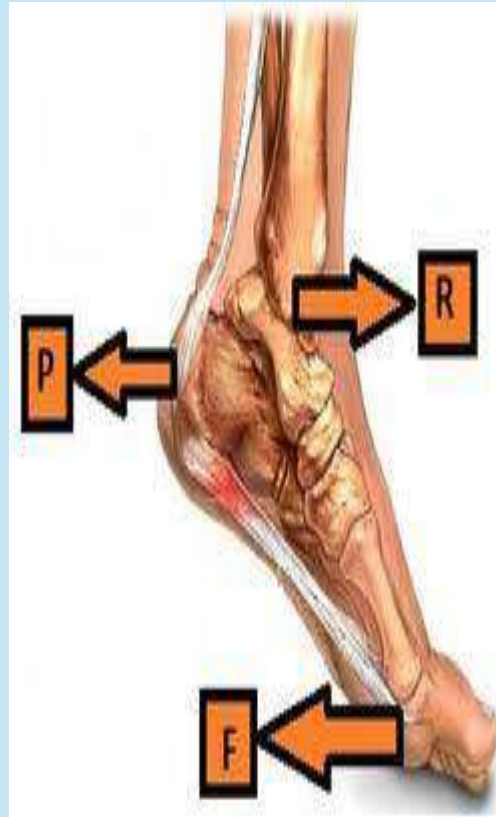

Se cuenta que el propio Galileo Galilei habría dicho:
"Dadme un punto de apoyo y moveré el mundo"



WeDo



ELABOLANDO PALANCAS DEL PRIMER TIPO Ó INTER-APOYANTE

1

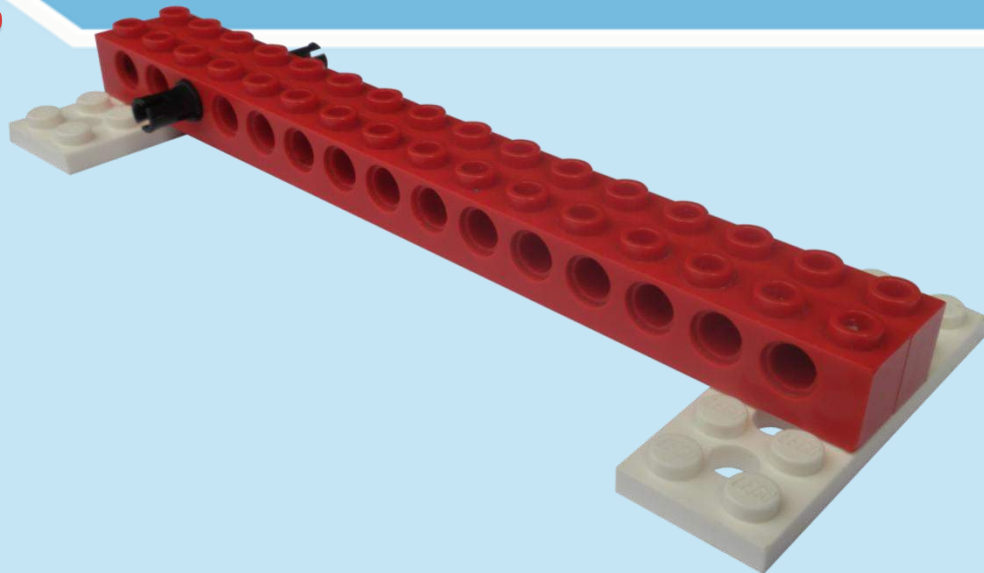

2

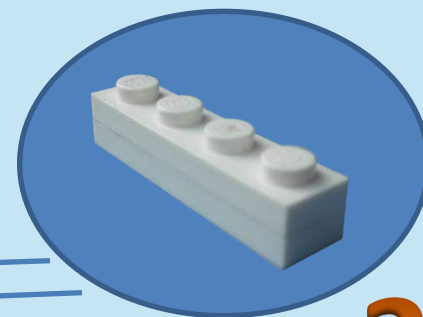
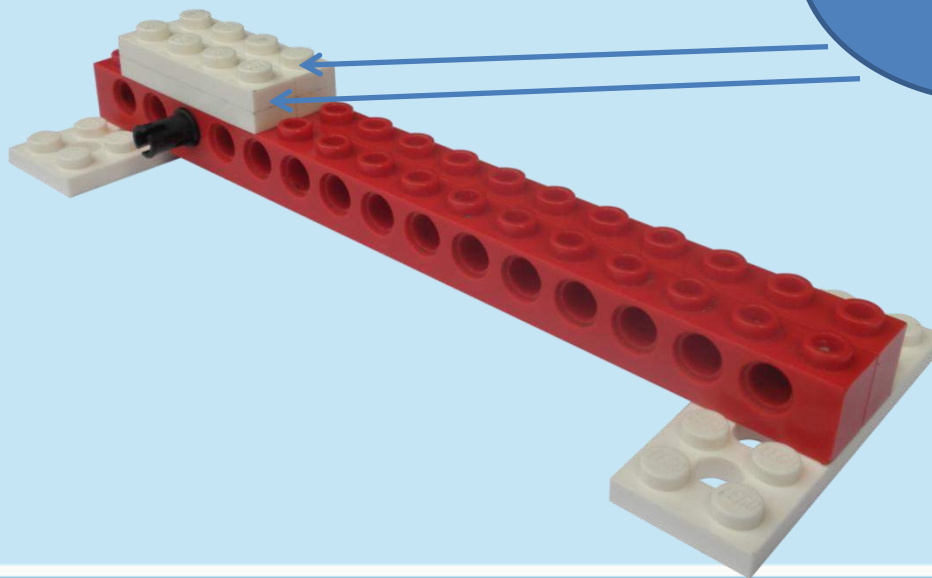

x2

3

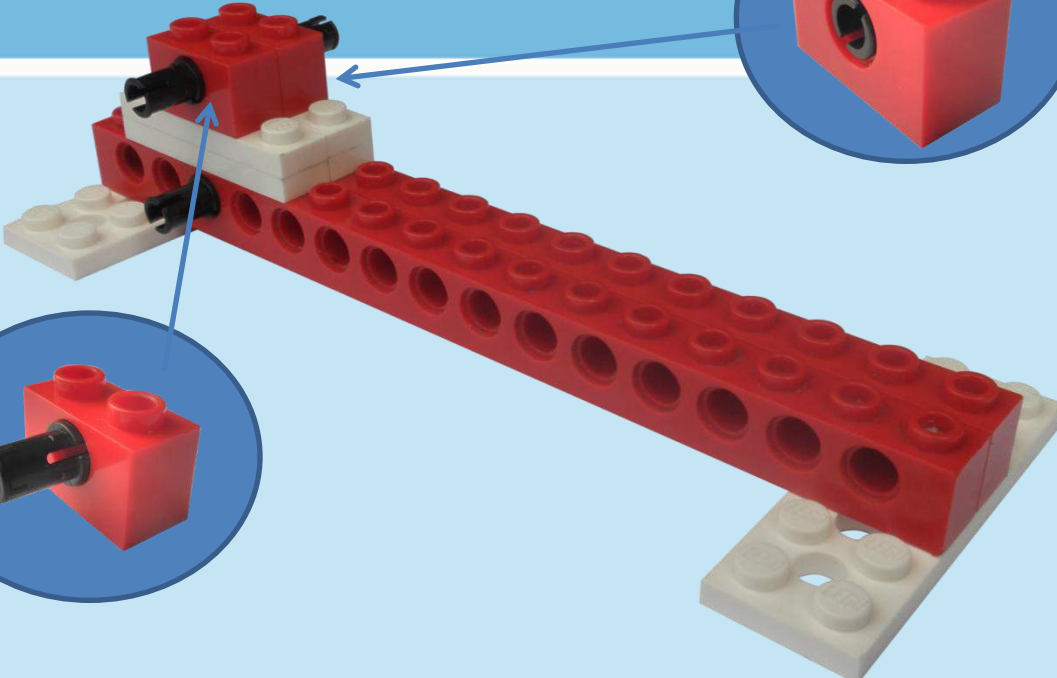
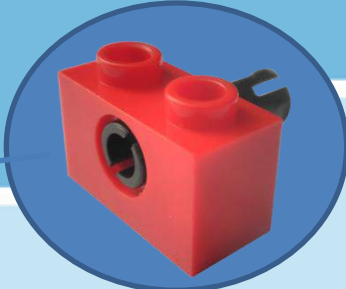

4

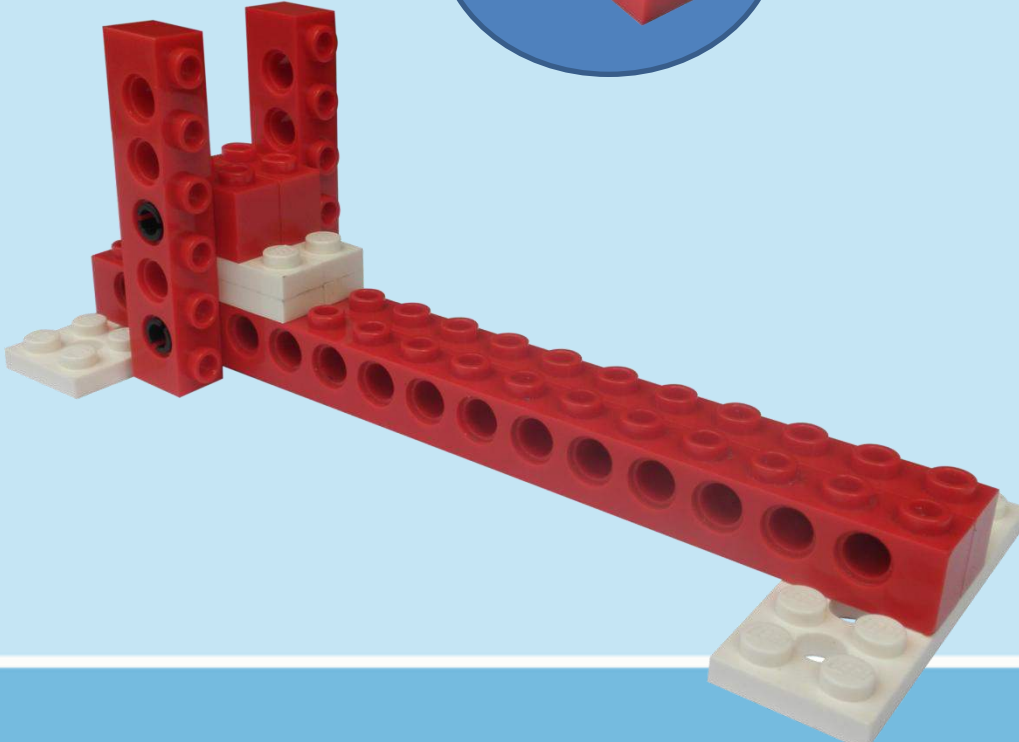
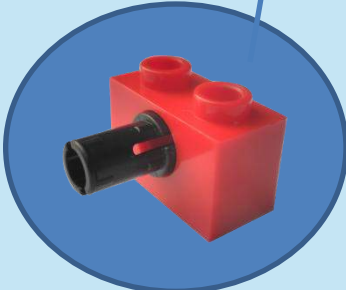

5

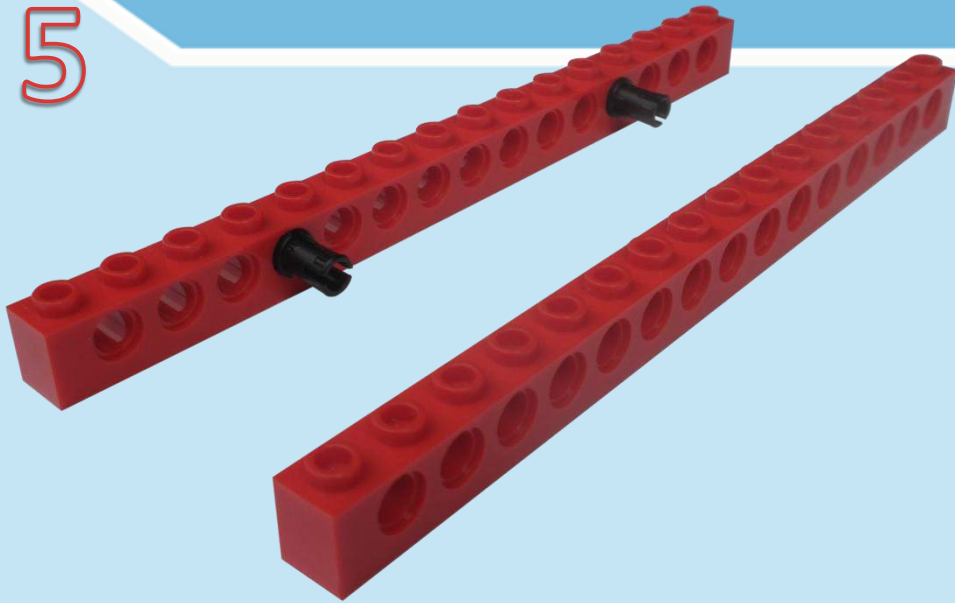

6

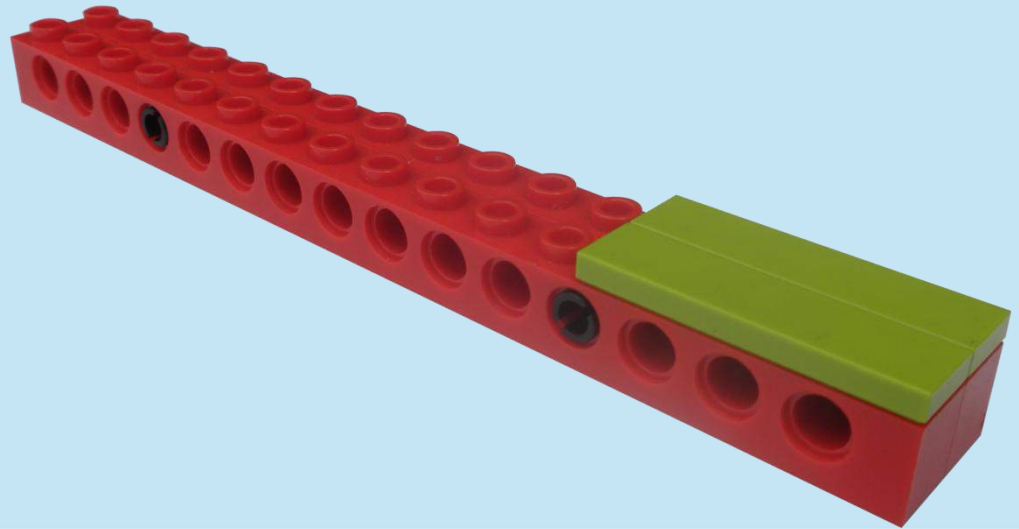

7

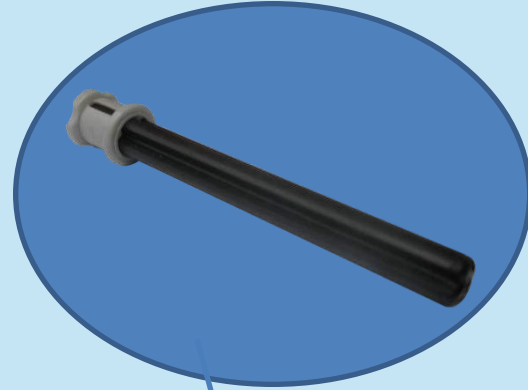
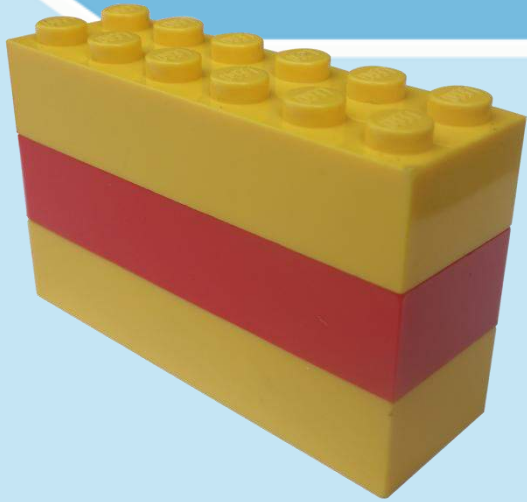

8

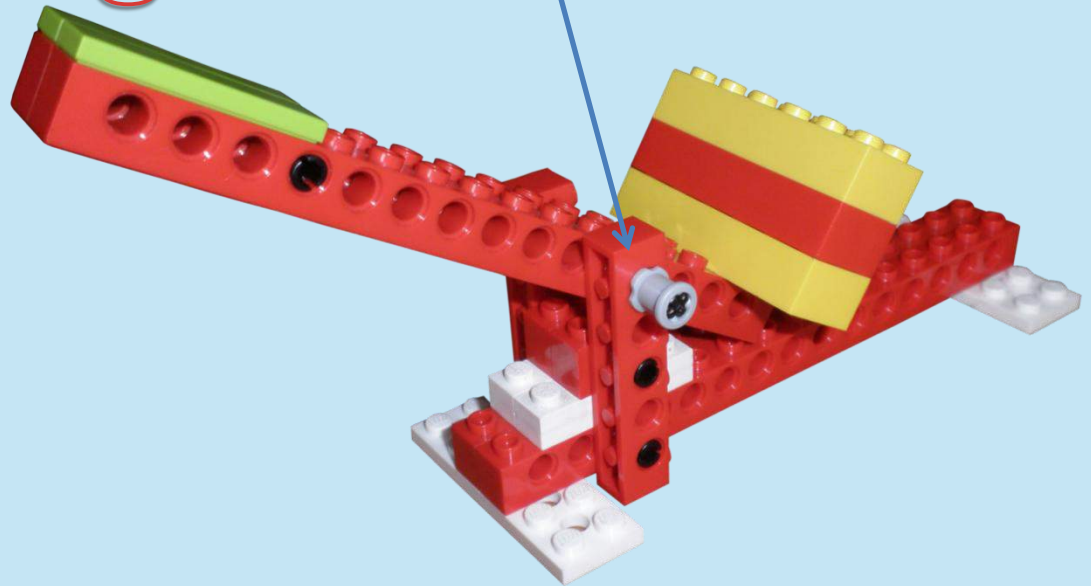

● Primer tipo ó Inter-apoyante.

FUERZA

CARGA

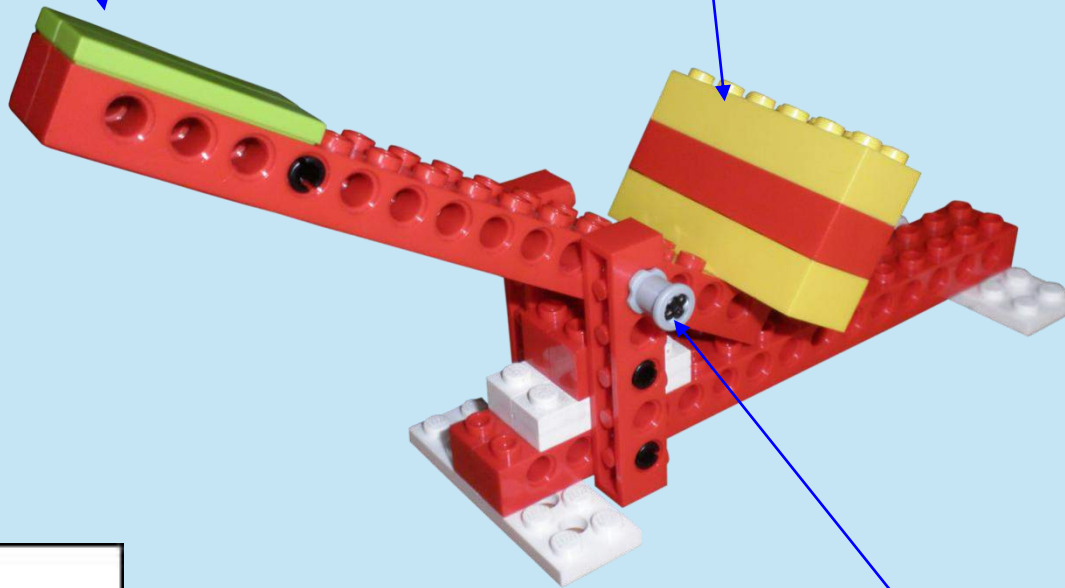

PUNTO DE APOYO



F

P.A

C

● Segundo tipo ó Inter-resistente.

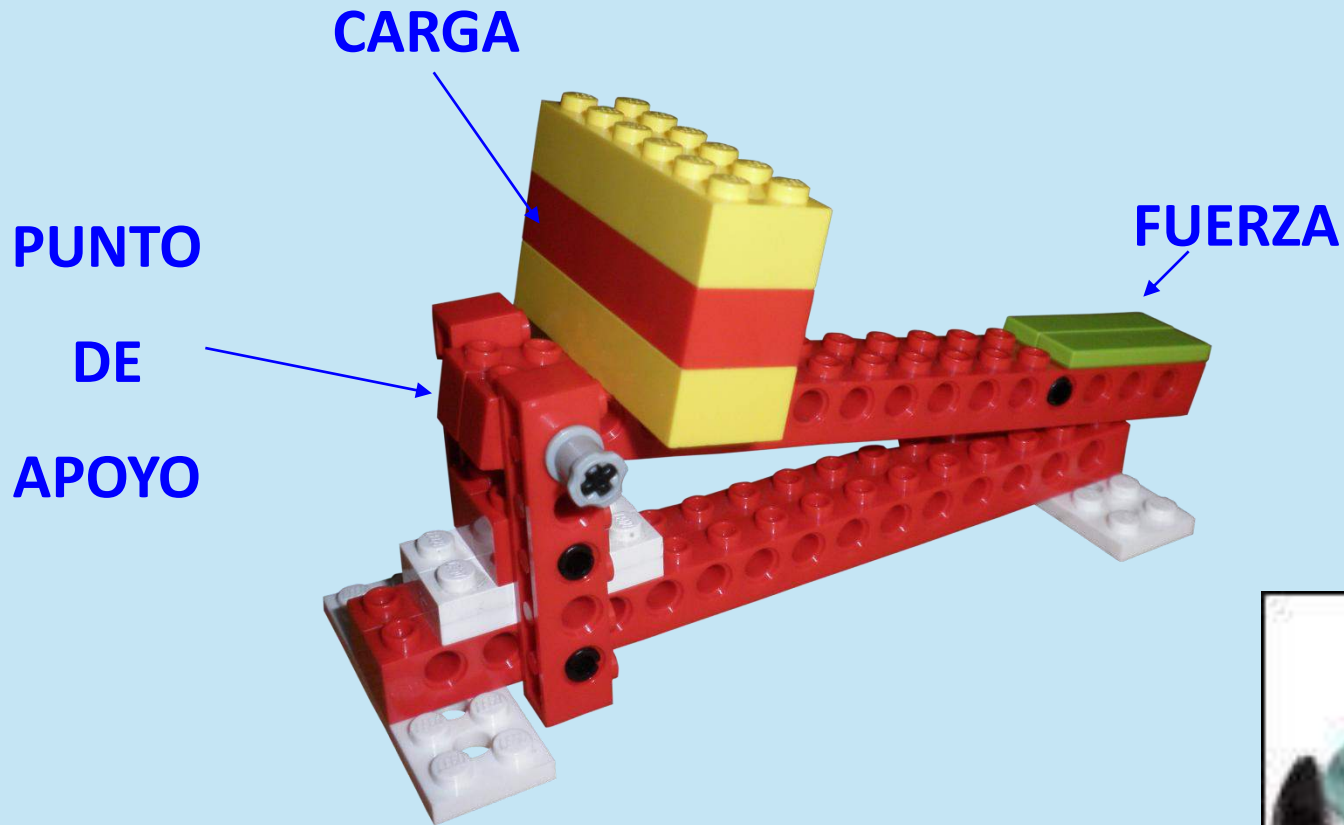

P.A C F



● Tercer tipo ó Inter-potente.

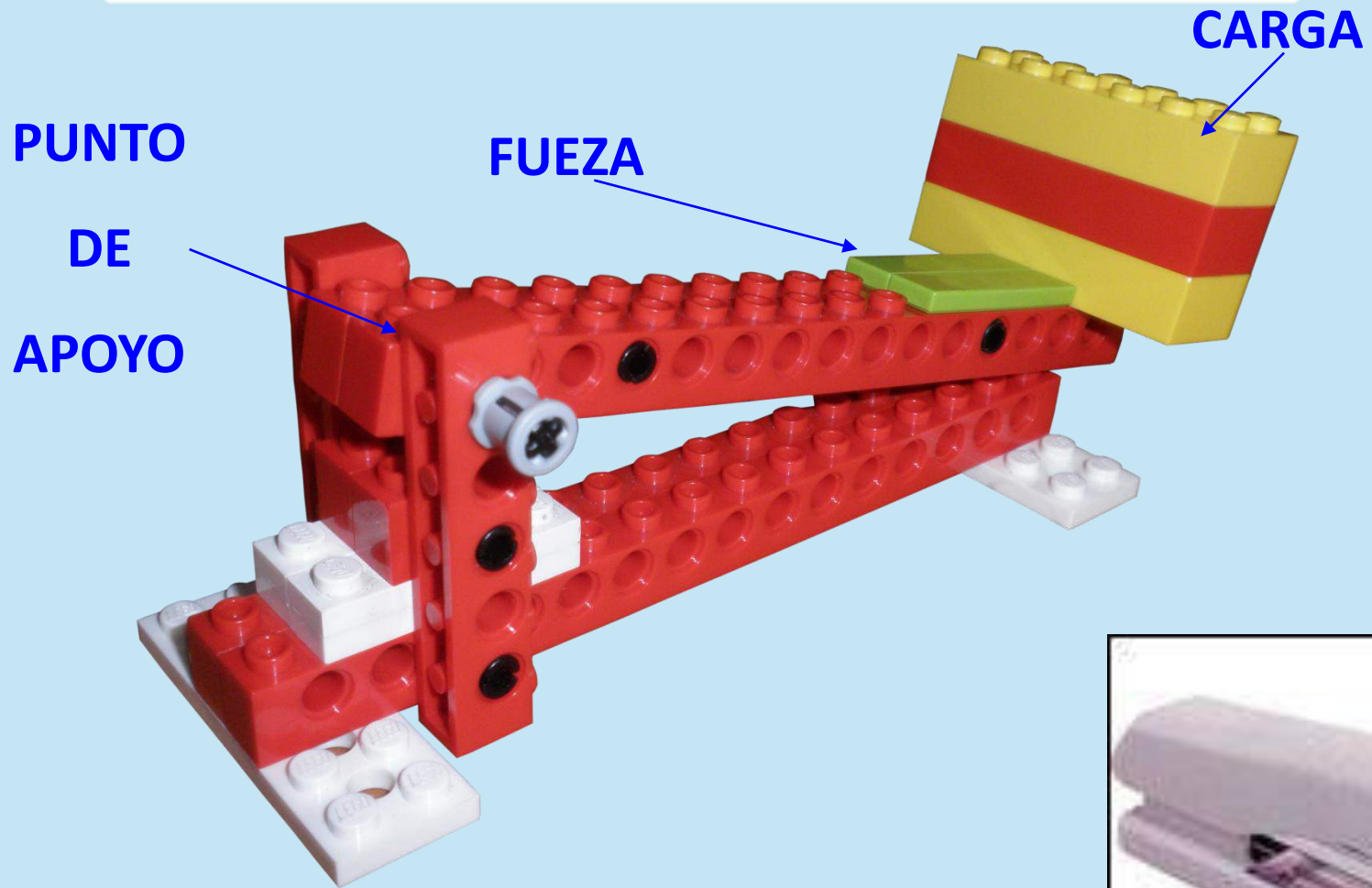

P.A F C



Limpiaparabrisas

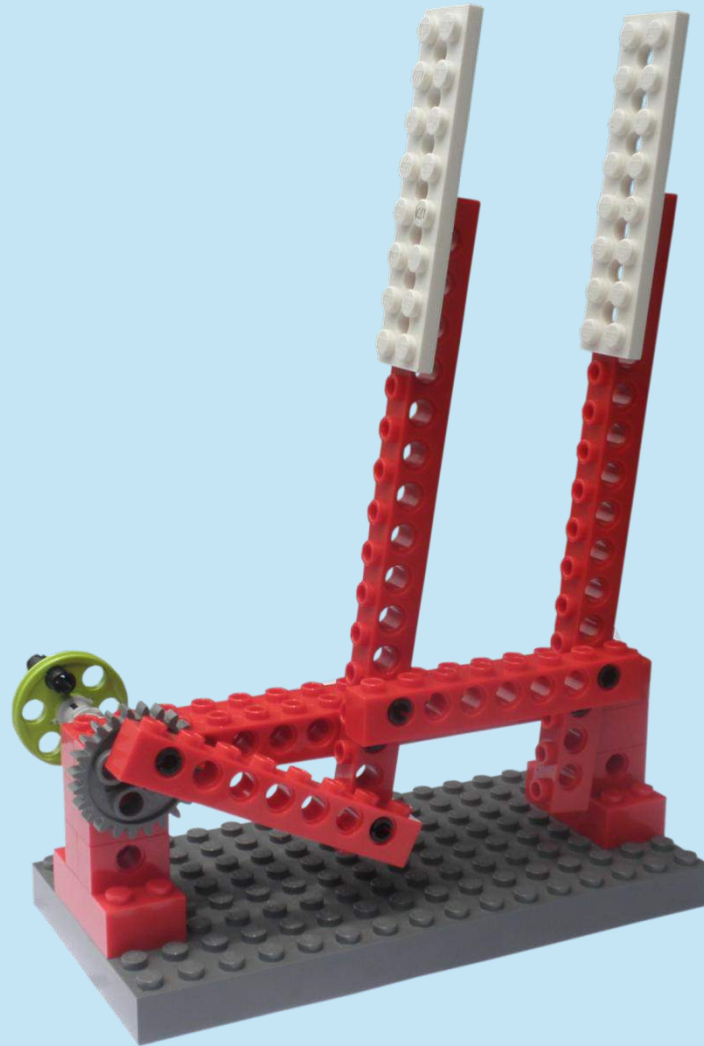

1

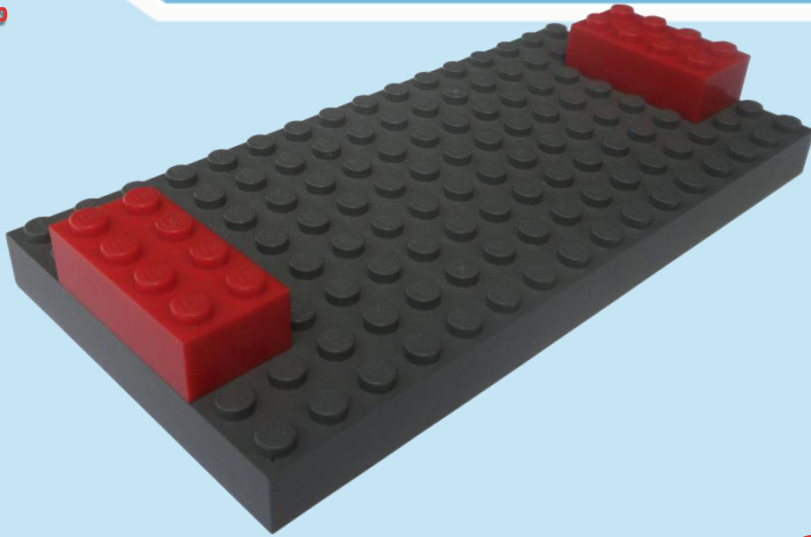

2

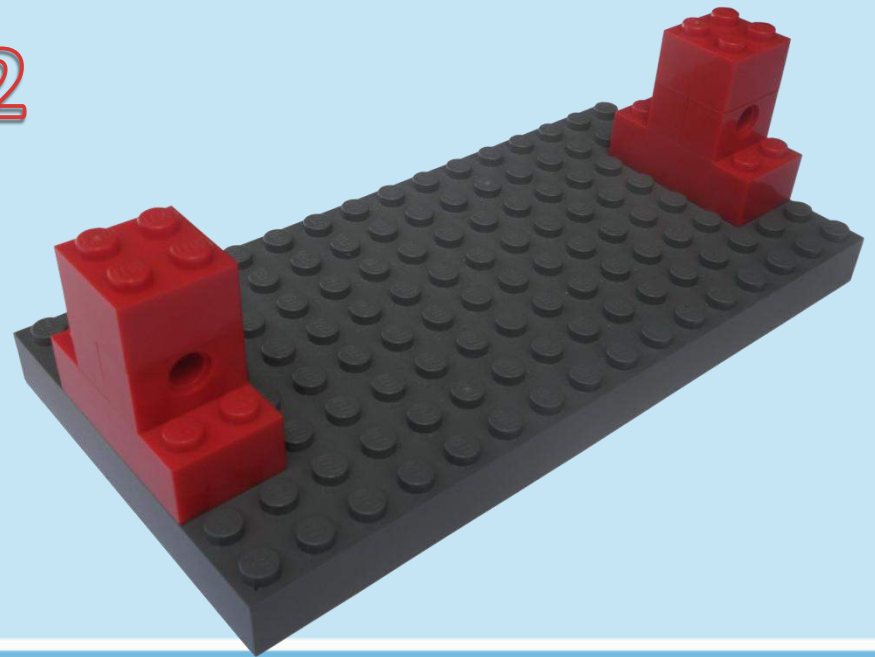

3

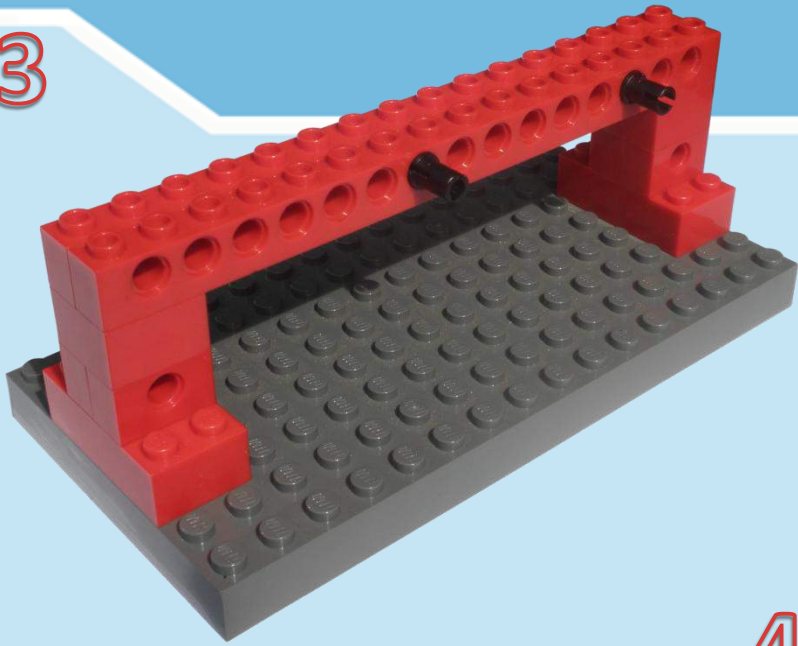

4

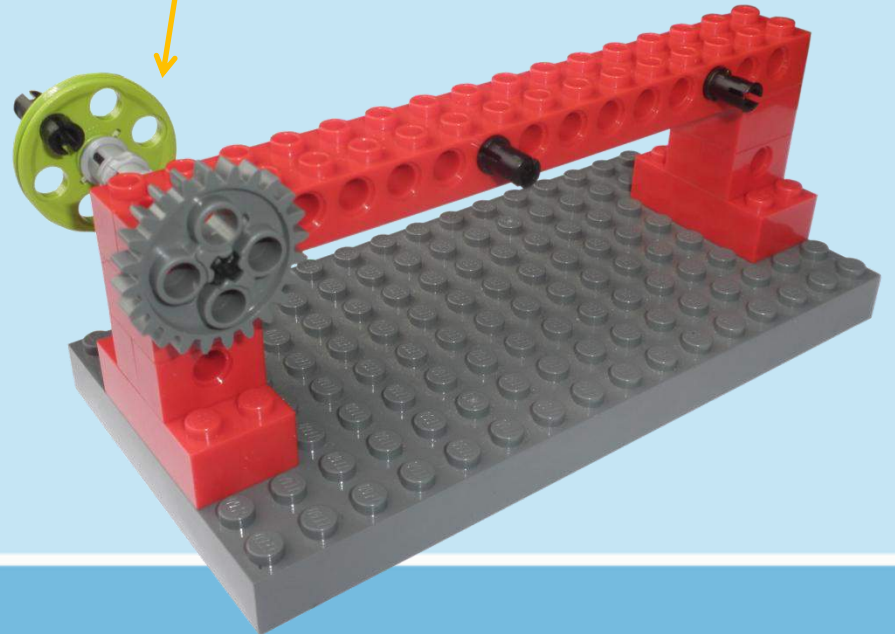

5

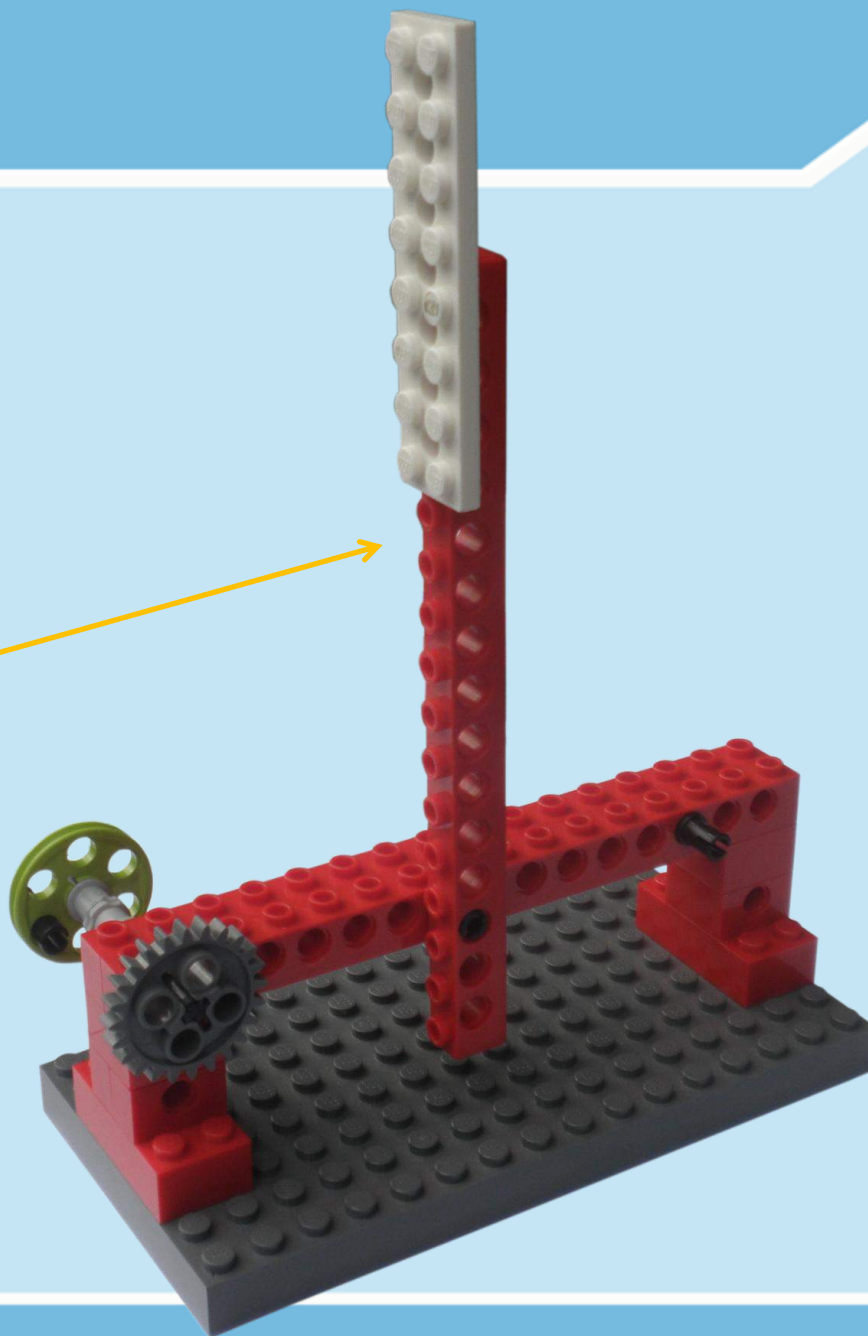
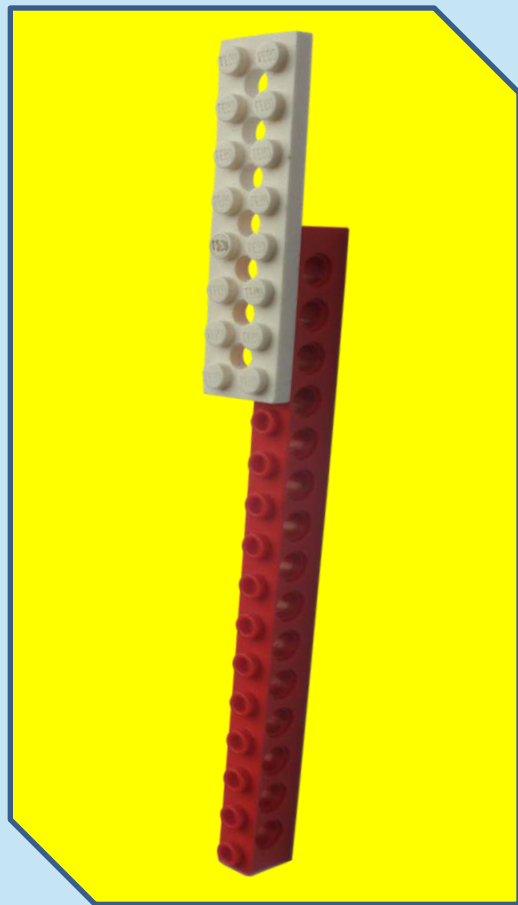

6

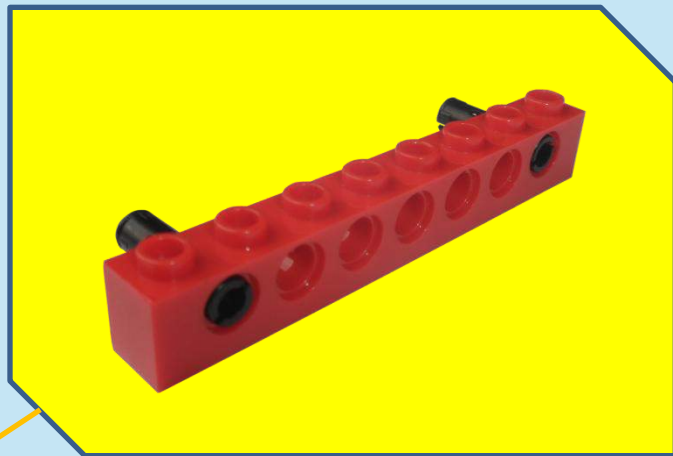
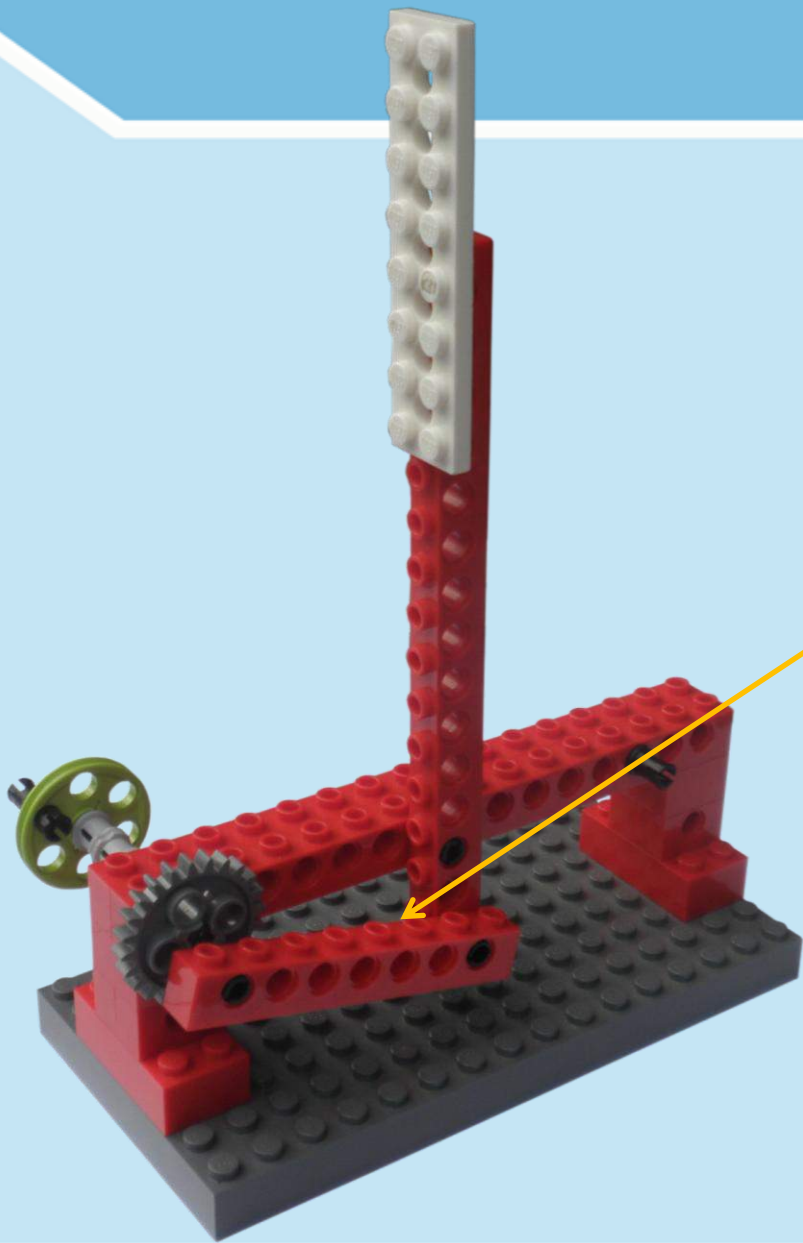

7

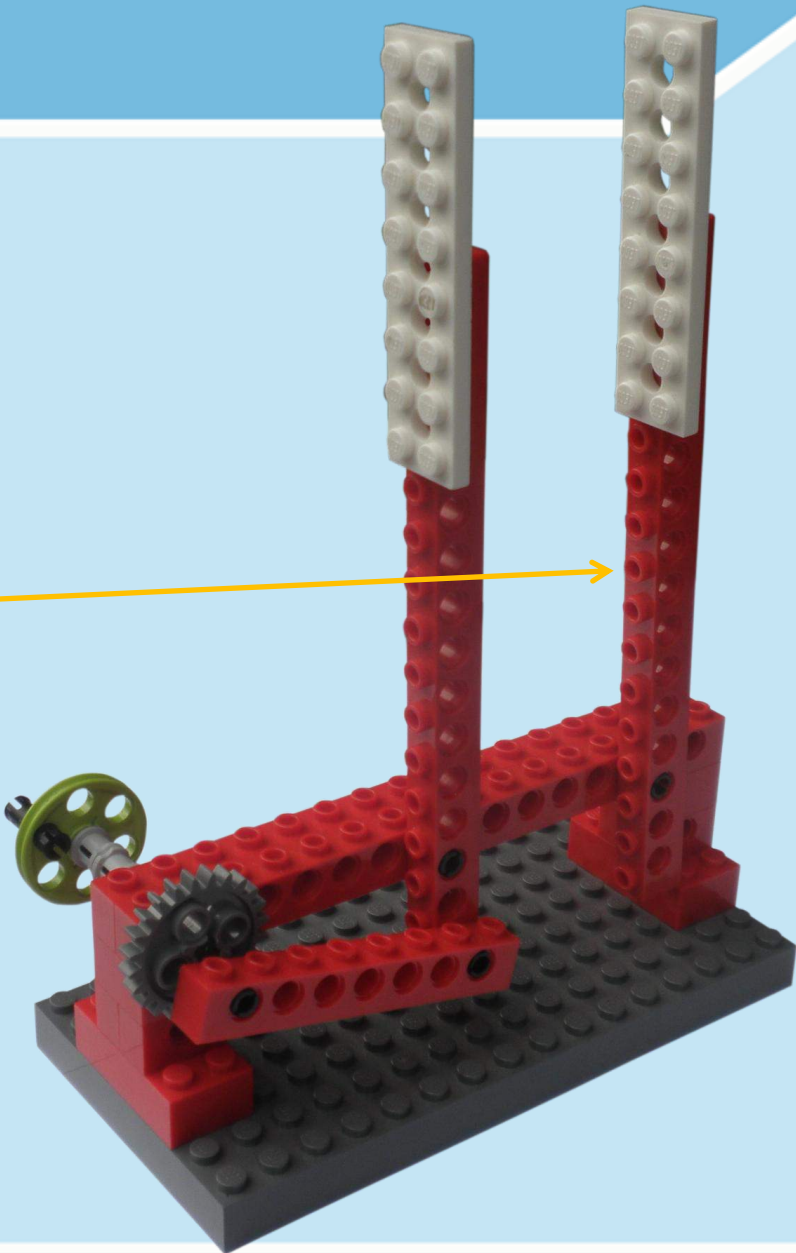
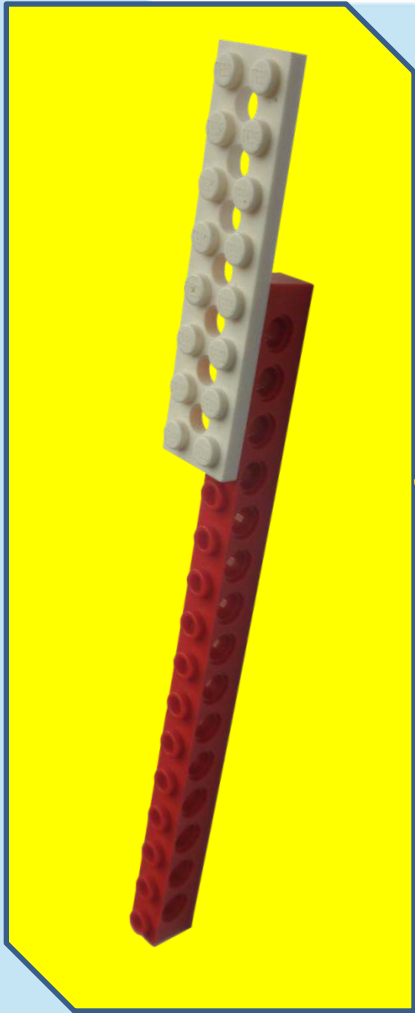

8

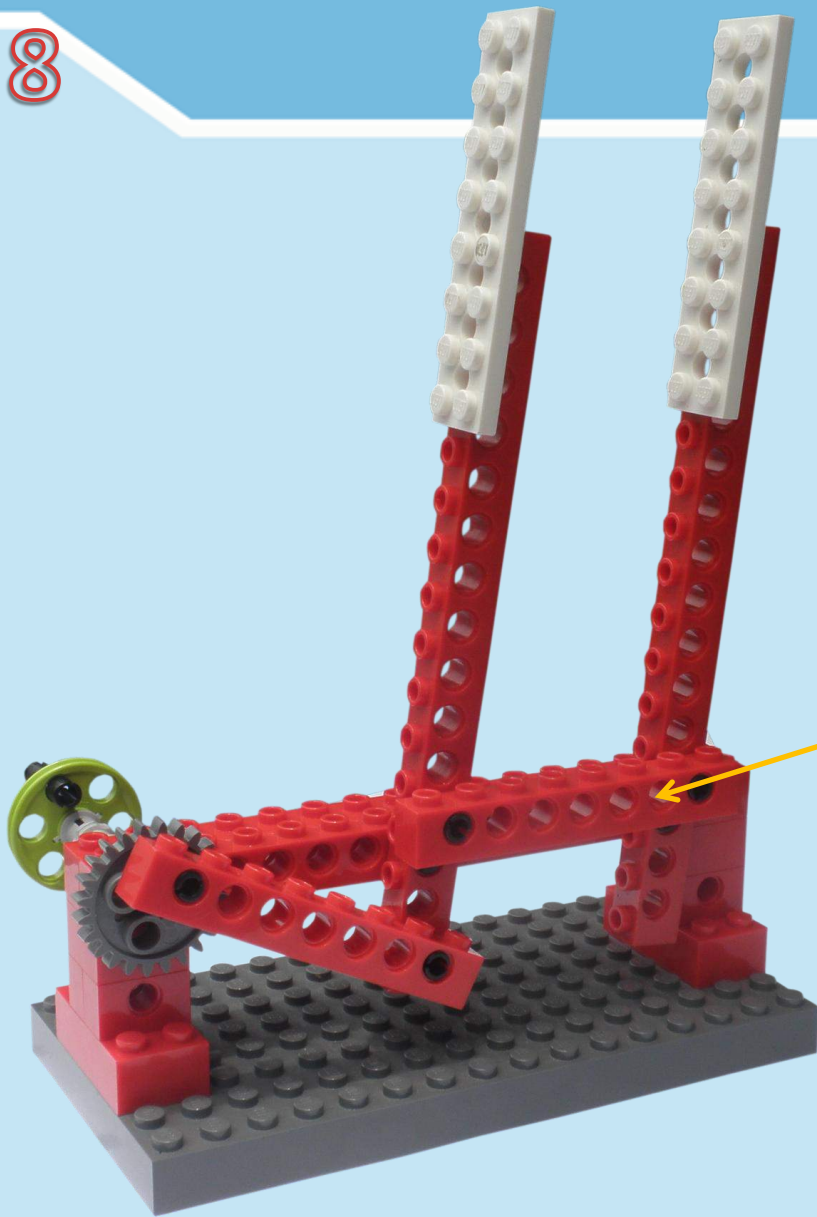

POLEAS



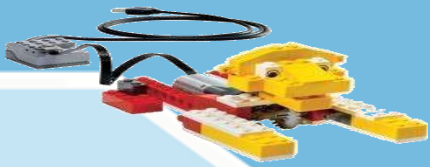

POLEAS

Las poleas son ruedas que tienen el perímetro exterior diseñado especialmente para facilitar el contacto con cuerdas o correas. En toda polea se distinguen tres partes: cuerpo, cubo y garganta.

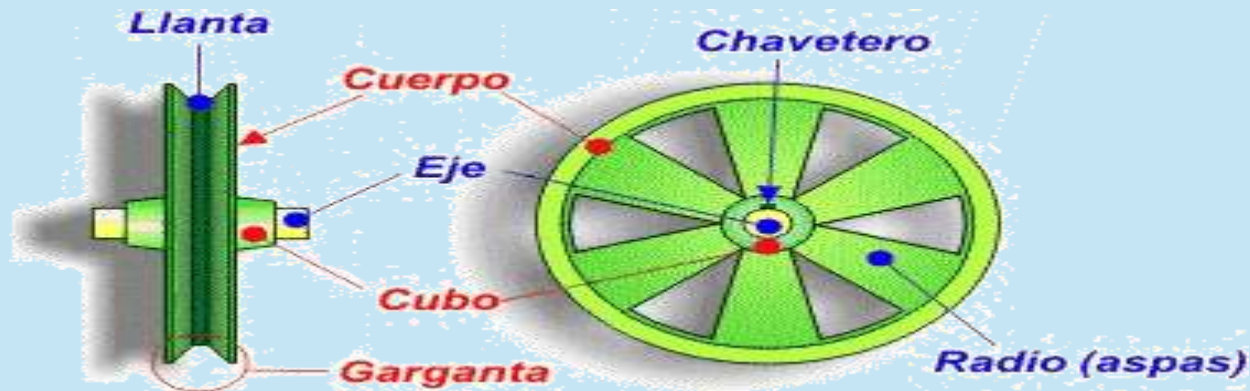

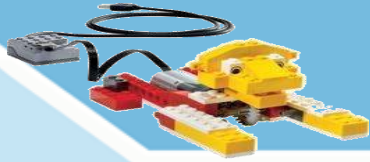

POLEAS



Como se conoce, las poleas son usadas en múltiples mecanismos utilizados en diversos que haceres productivos y muchos otros. Aquí se muestran algunos ejemplos:

Grúa

Bicicleta

Ascensor

Pozo de agua

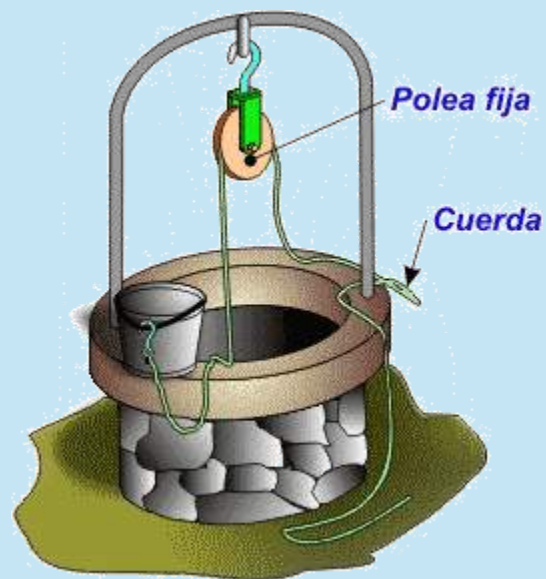
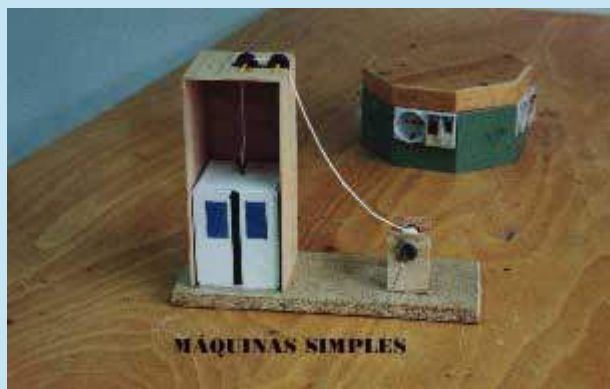
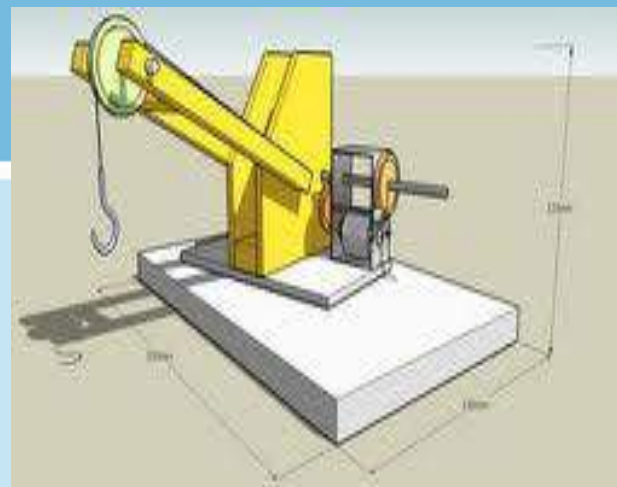

1

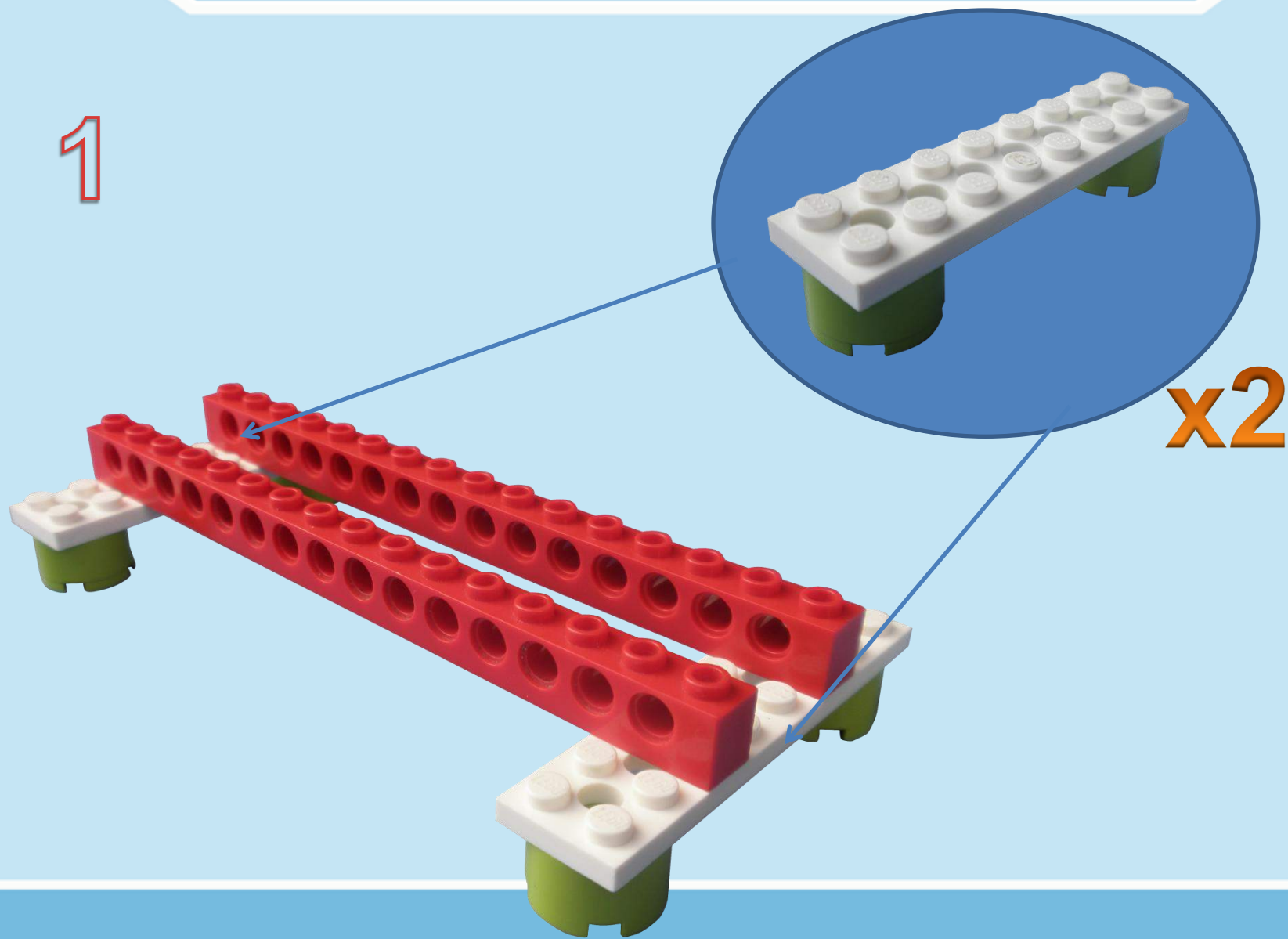

x2

● Principio I: Dirección de rotación

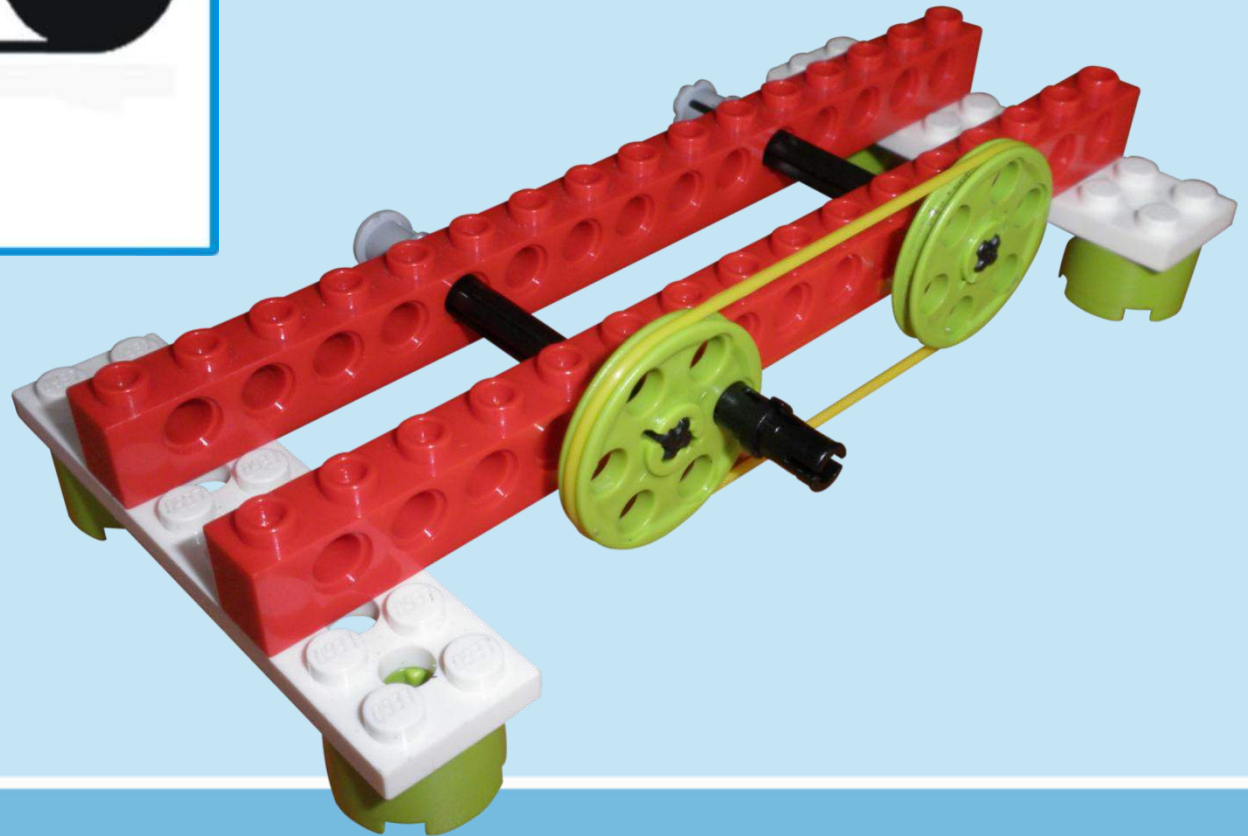
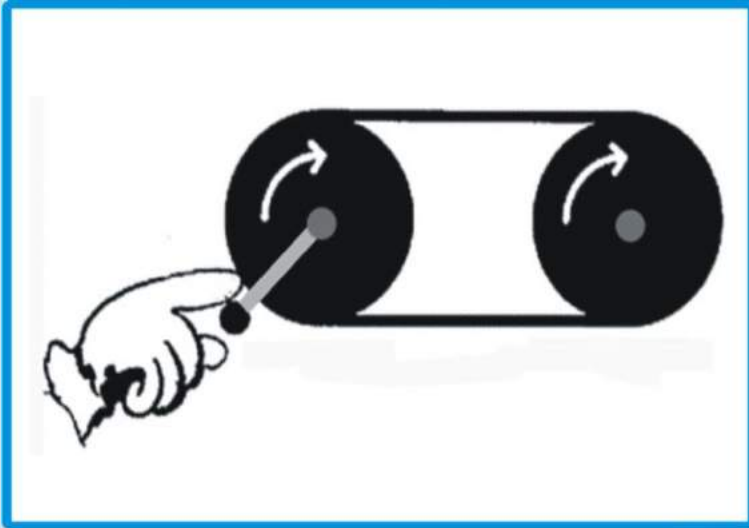

Principio II: Cambiando la dirección de la rotación

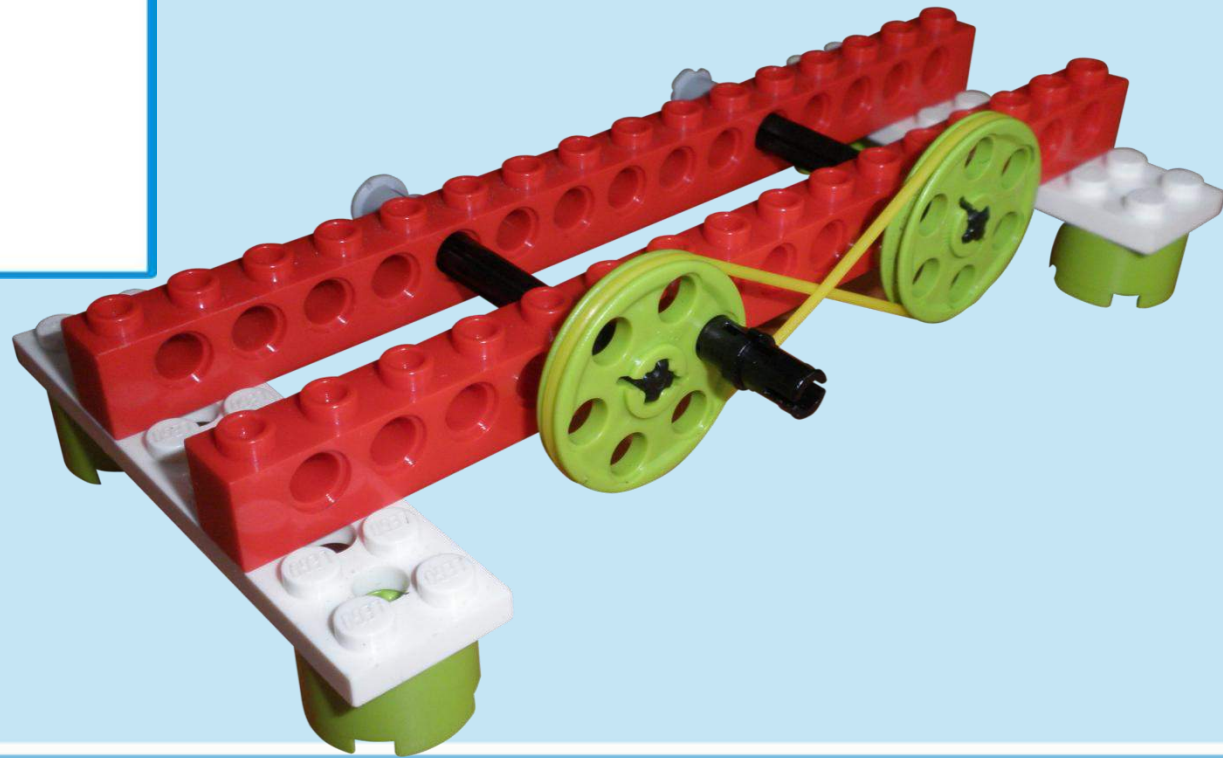
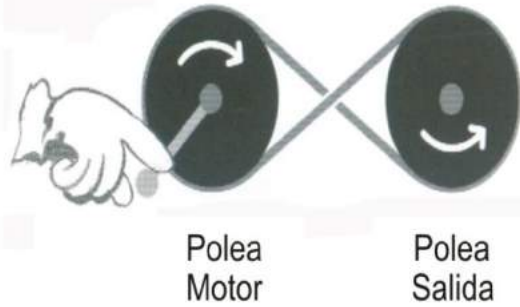

● Principio III: Reduciendo Velocidad

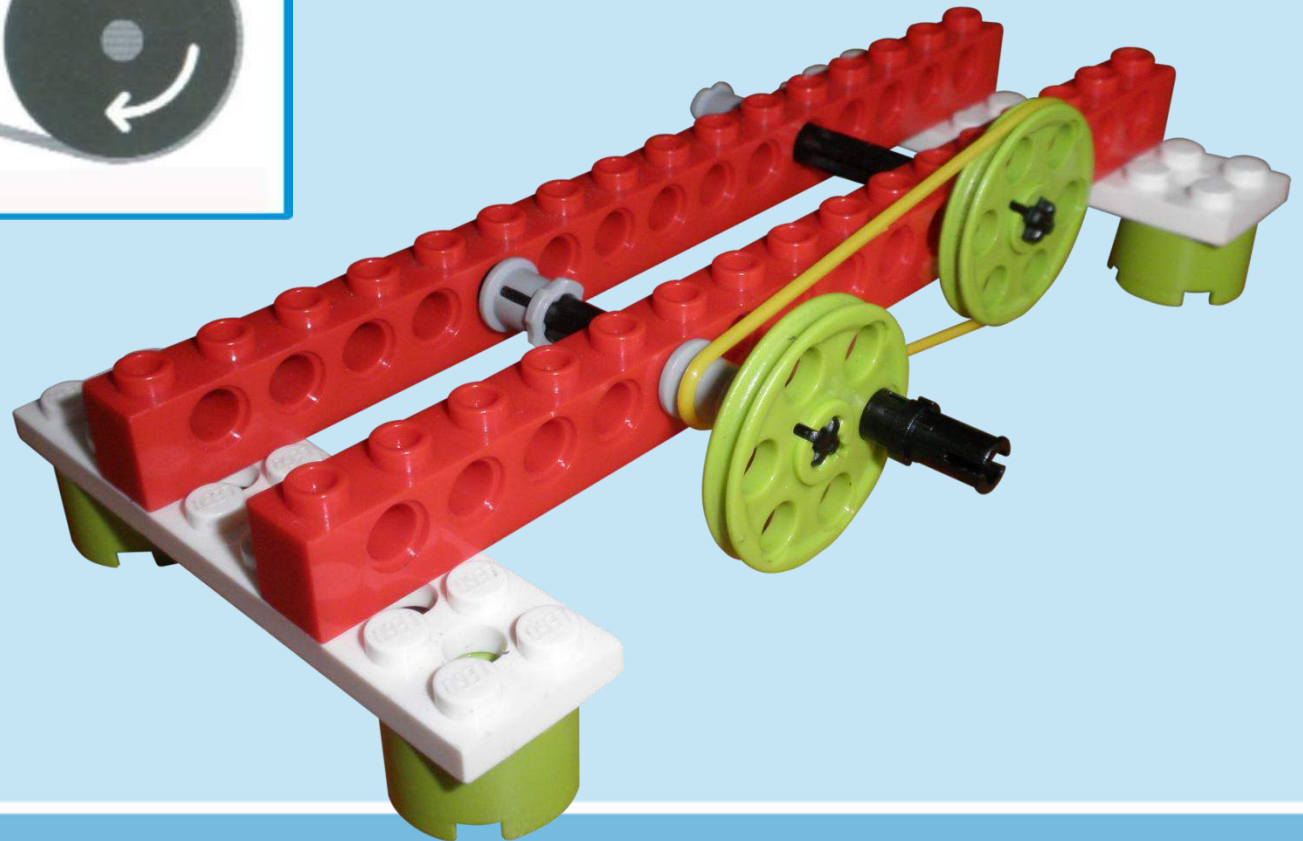
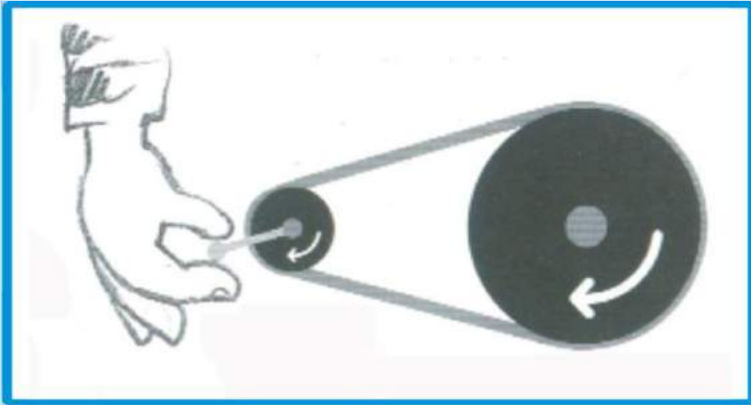

● Principio IV: Aumento de velocidad

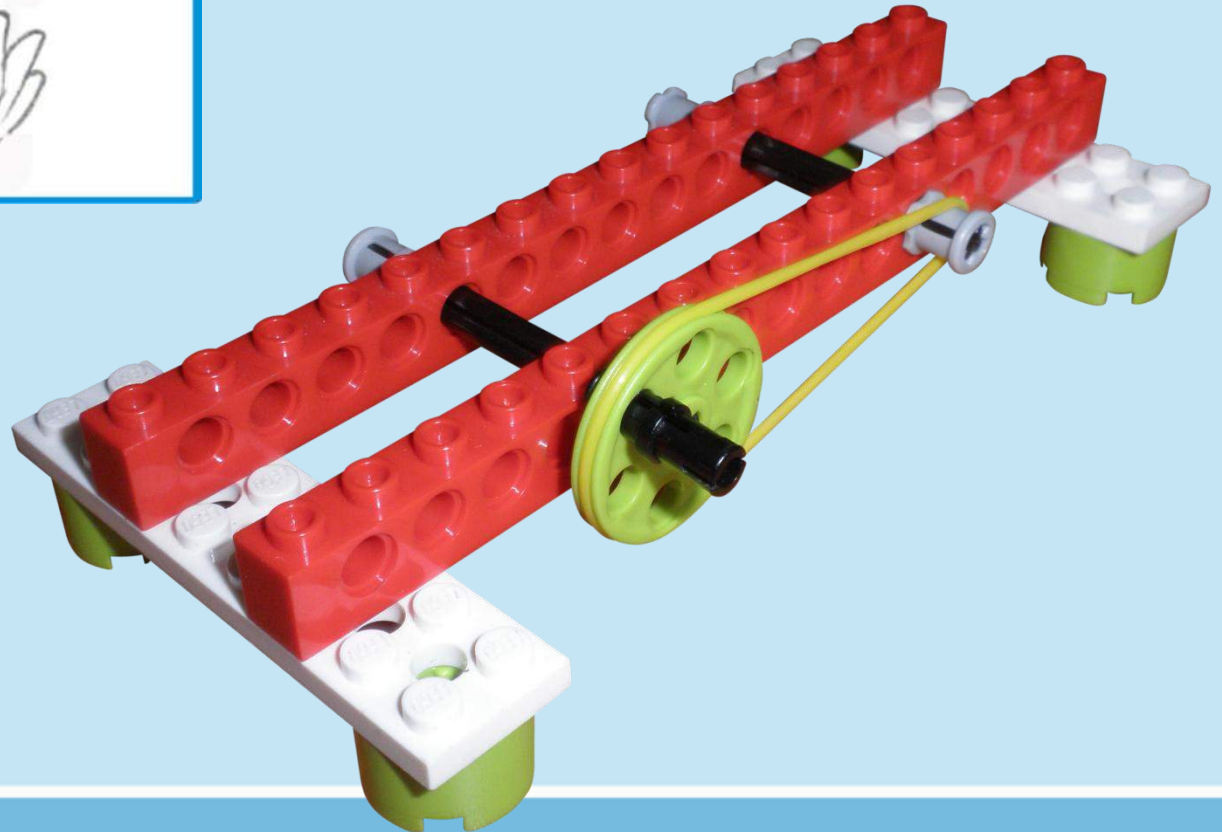
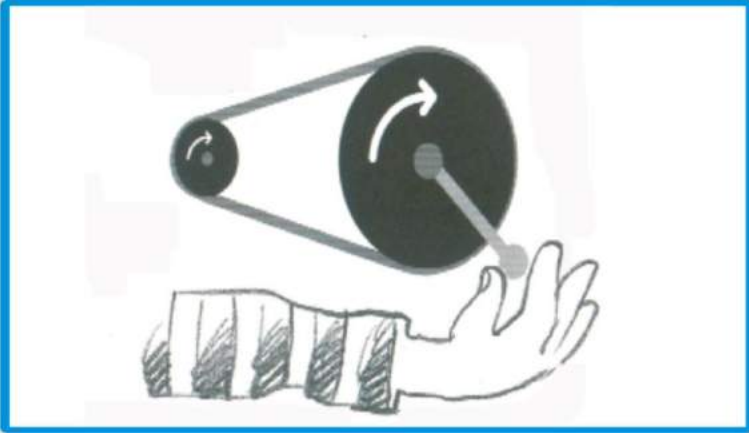

● Principio V: En ángulo

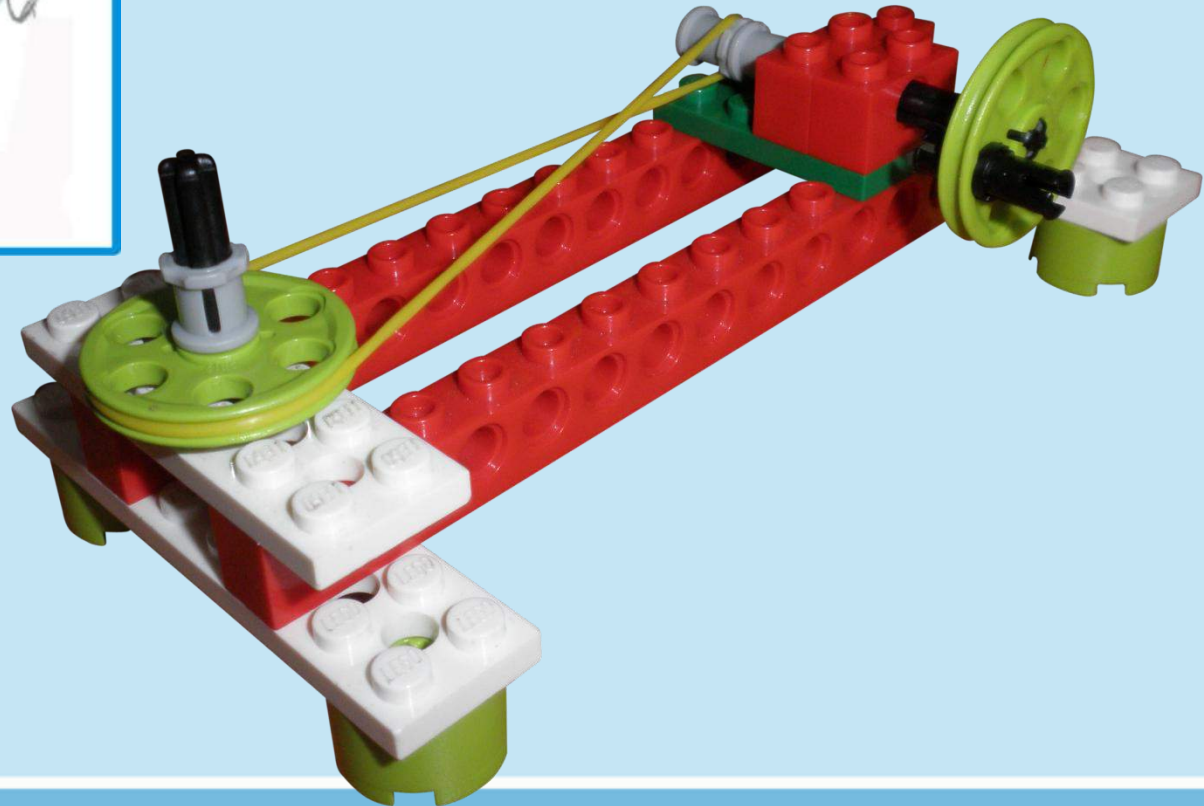
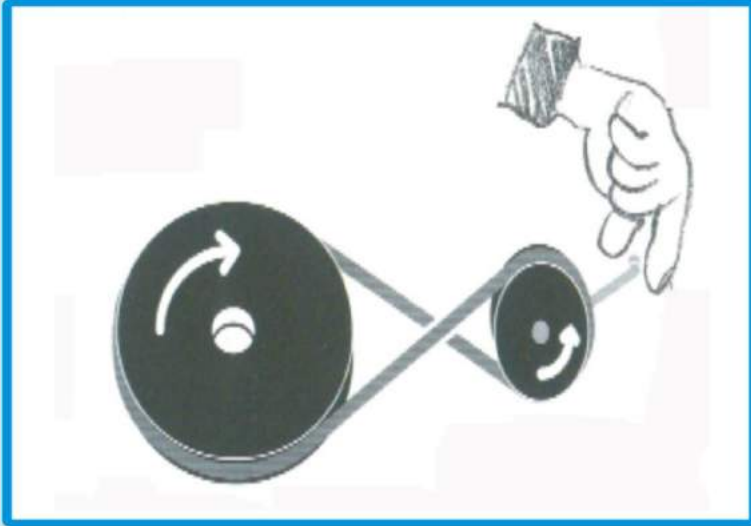

● Principio VI: Transmisiones por correa compuestas

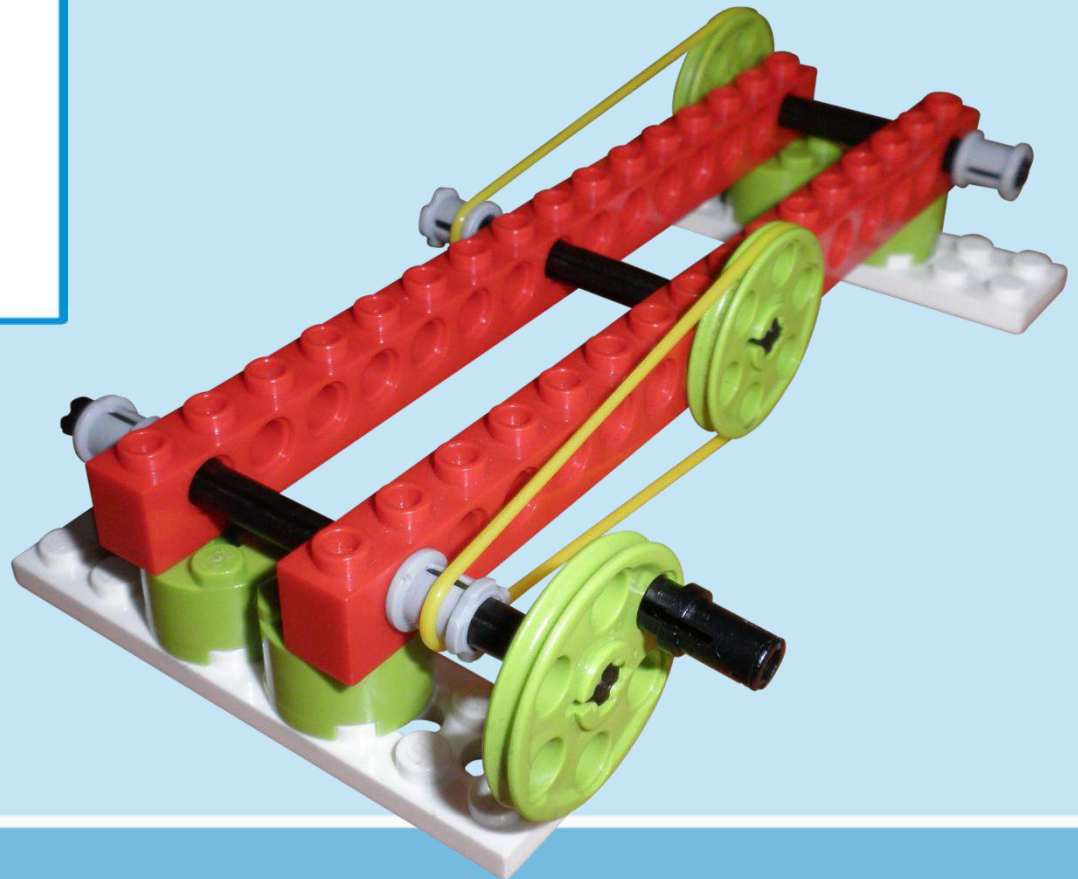
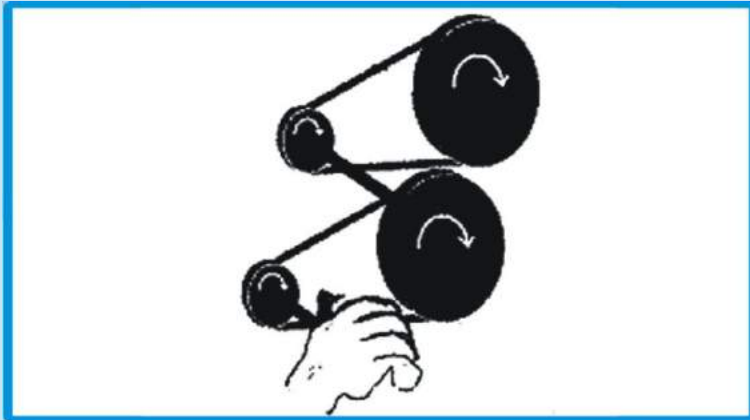

● Principio VII: Poleas fijas

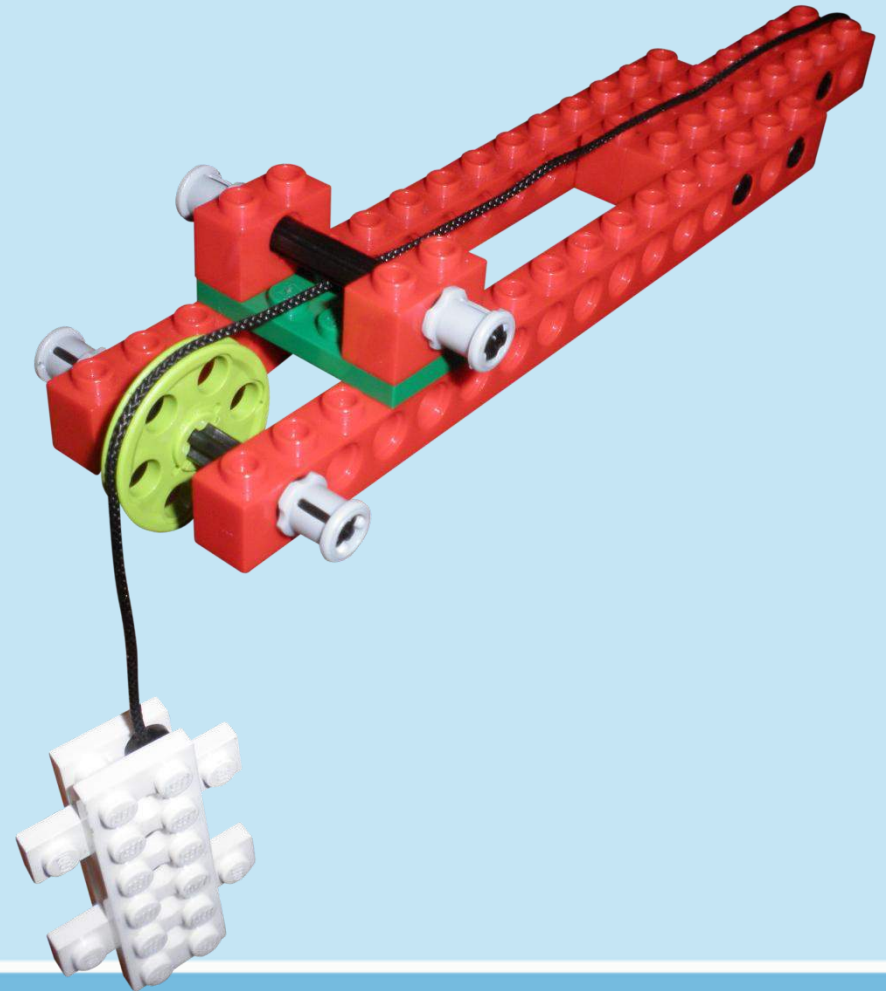

● Principio VIII: Poleas Móviles

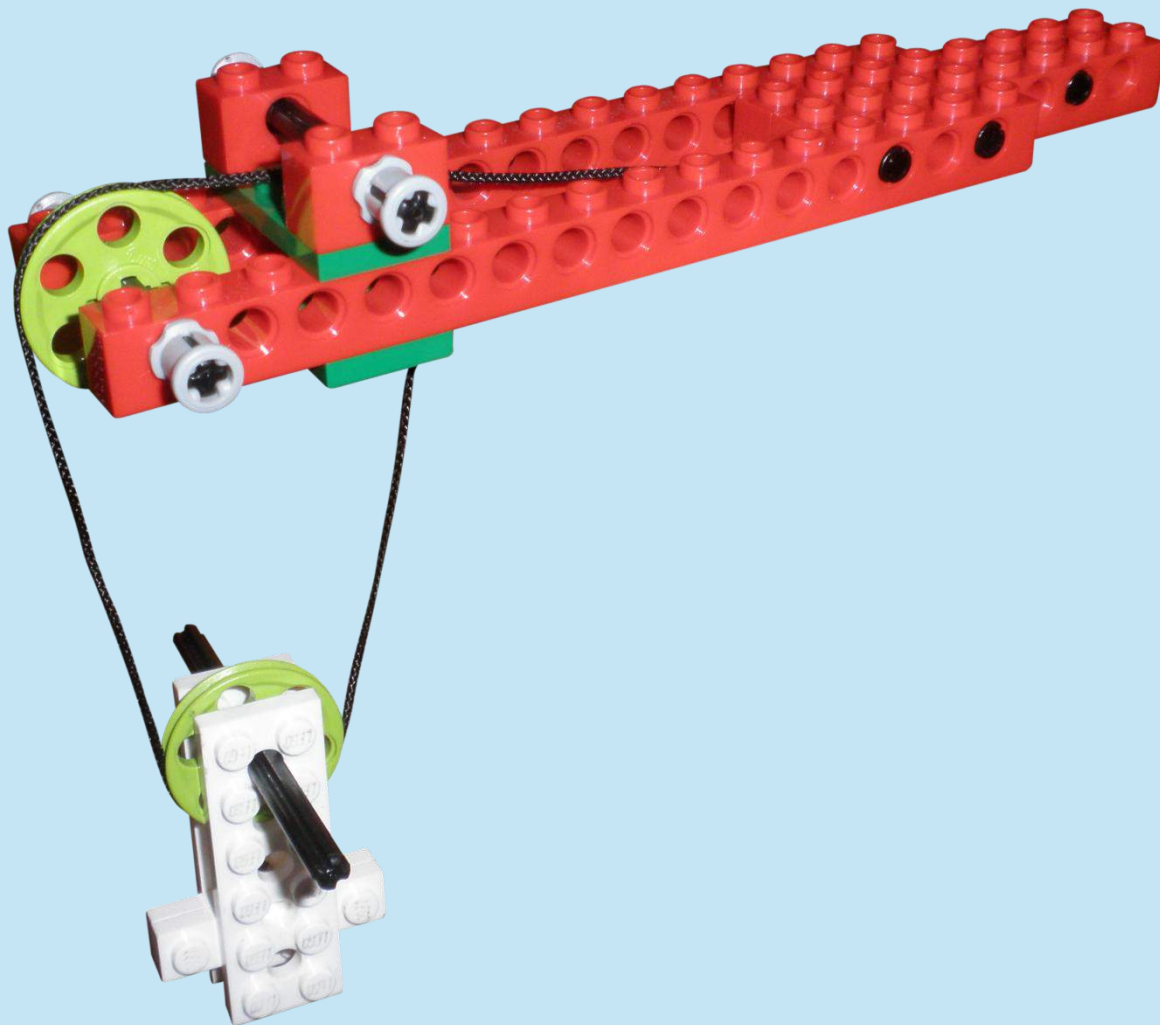
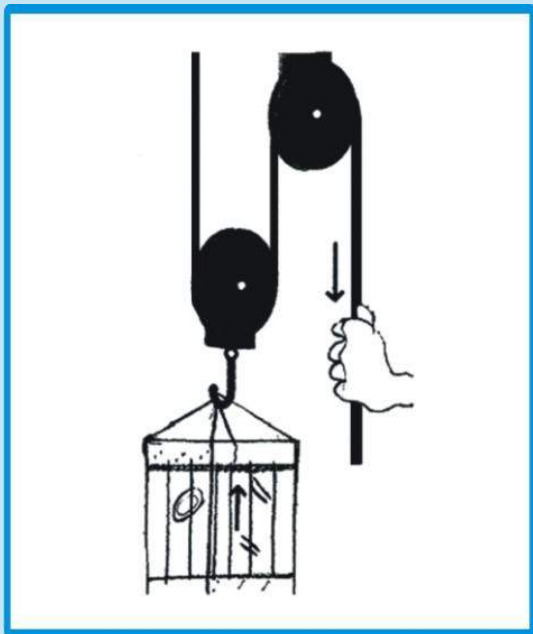

GRÚA LEGO



1

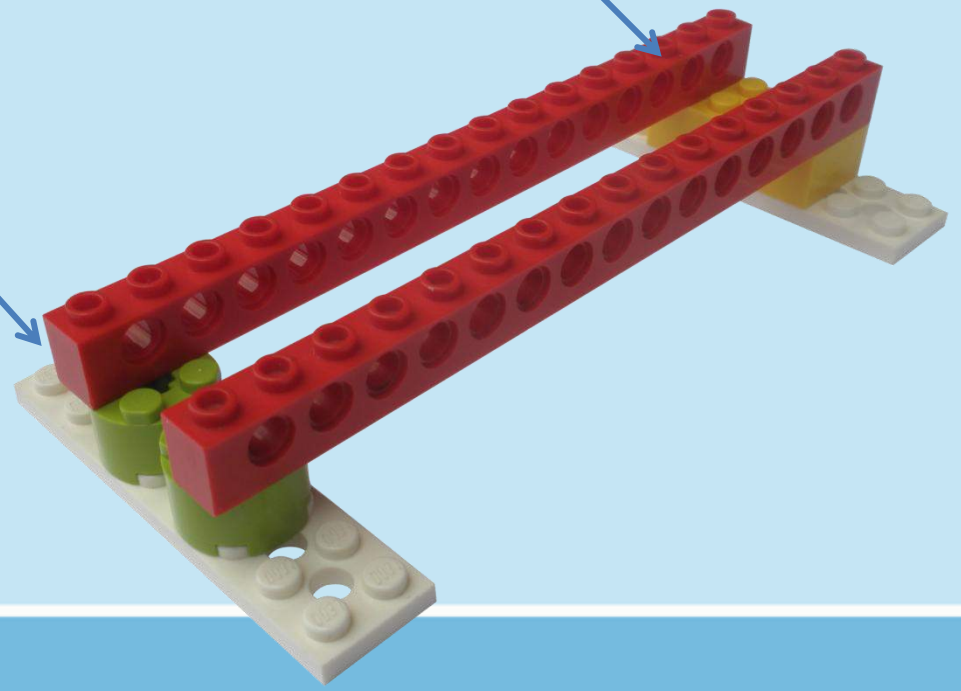
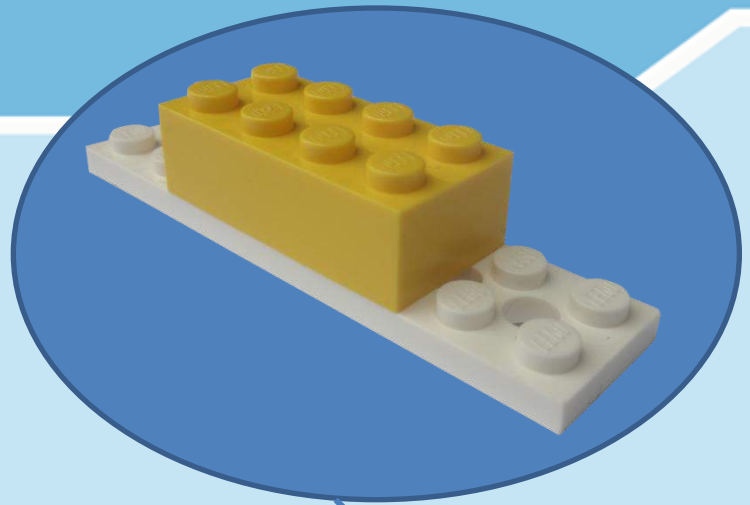
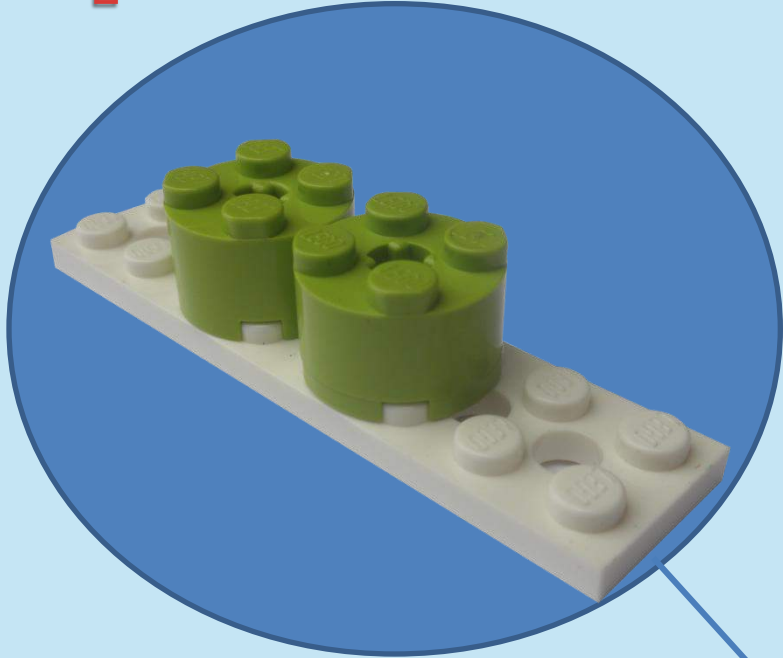

2

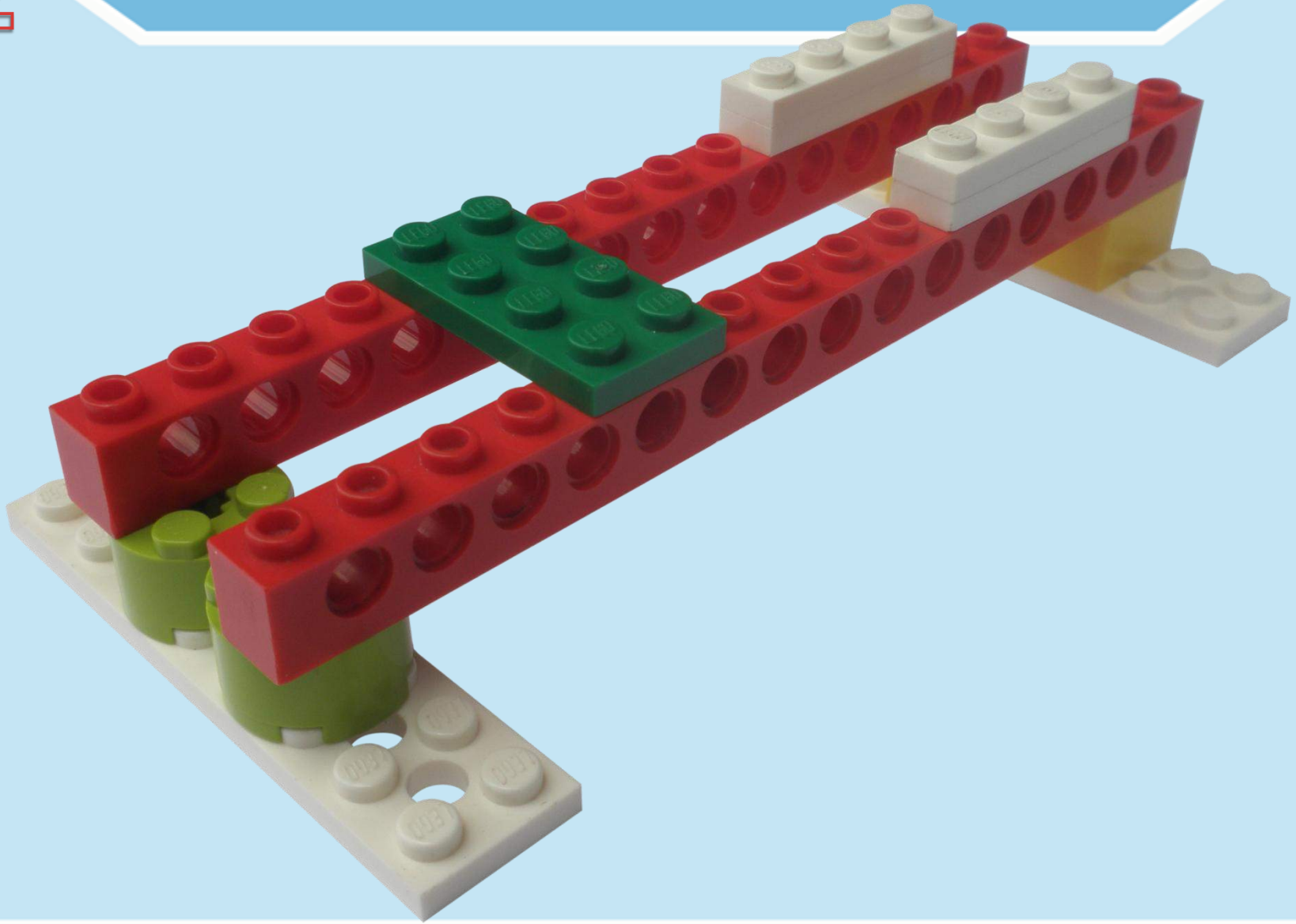

3

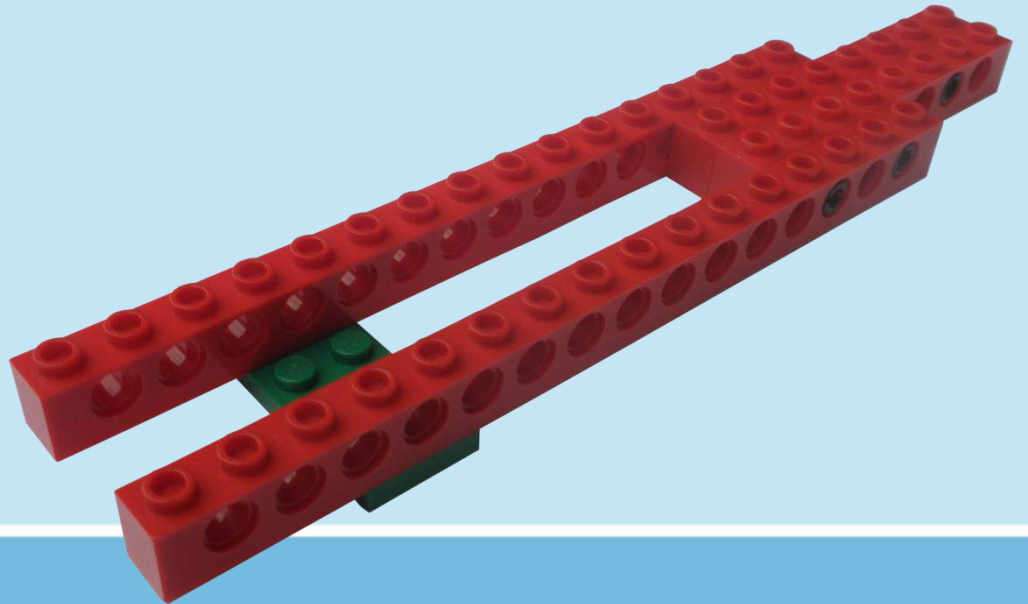
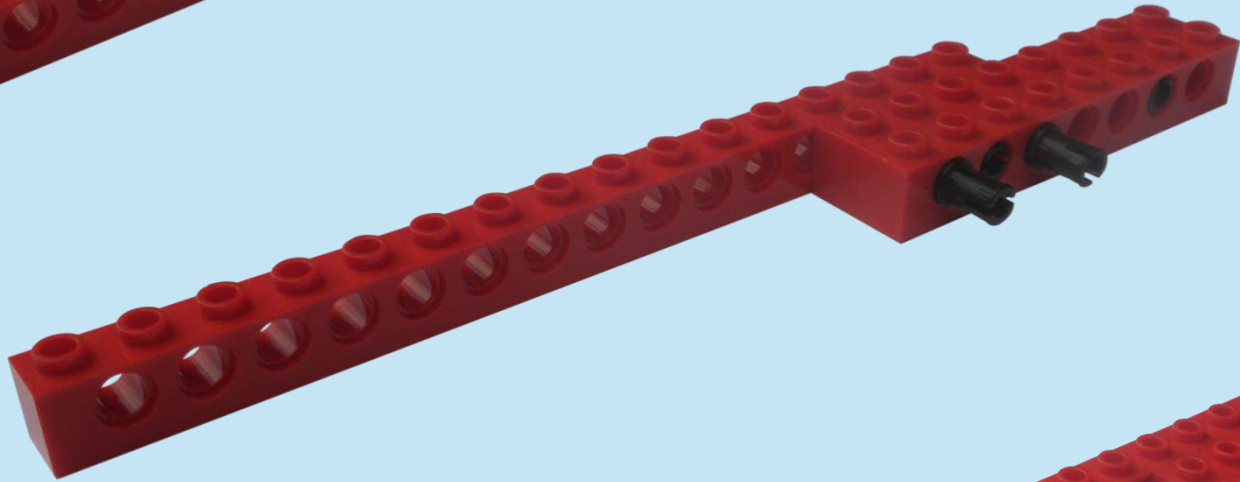
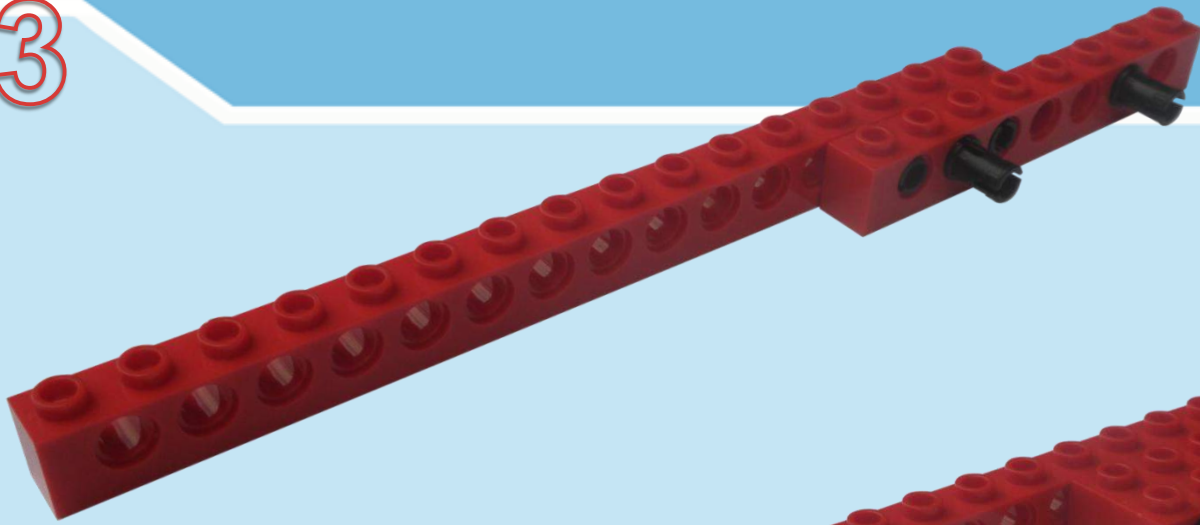

4

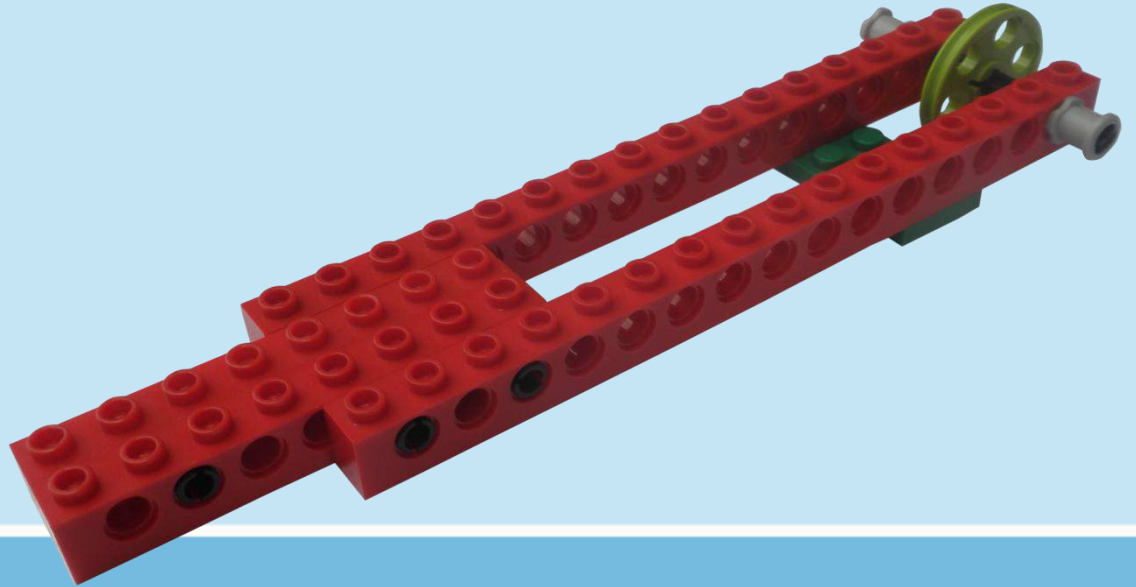
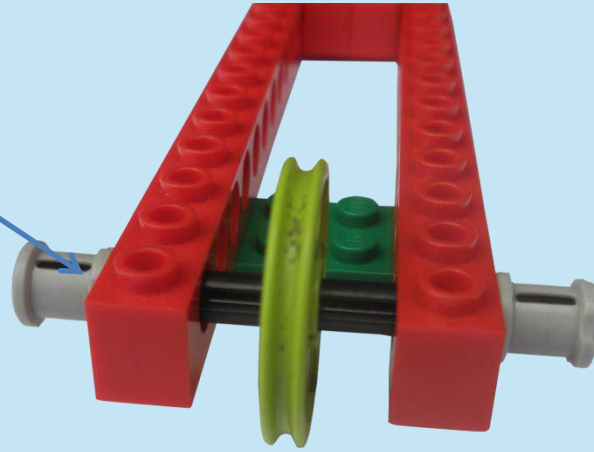
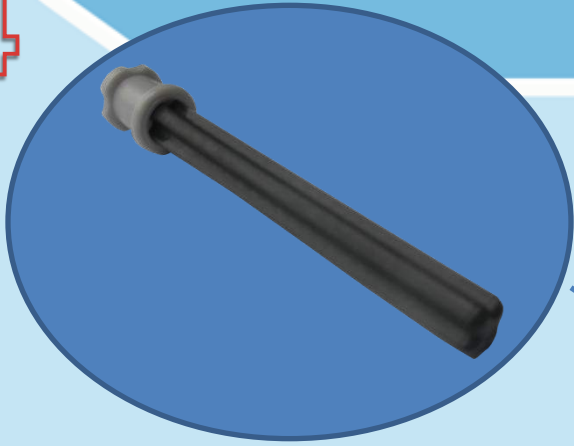

5

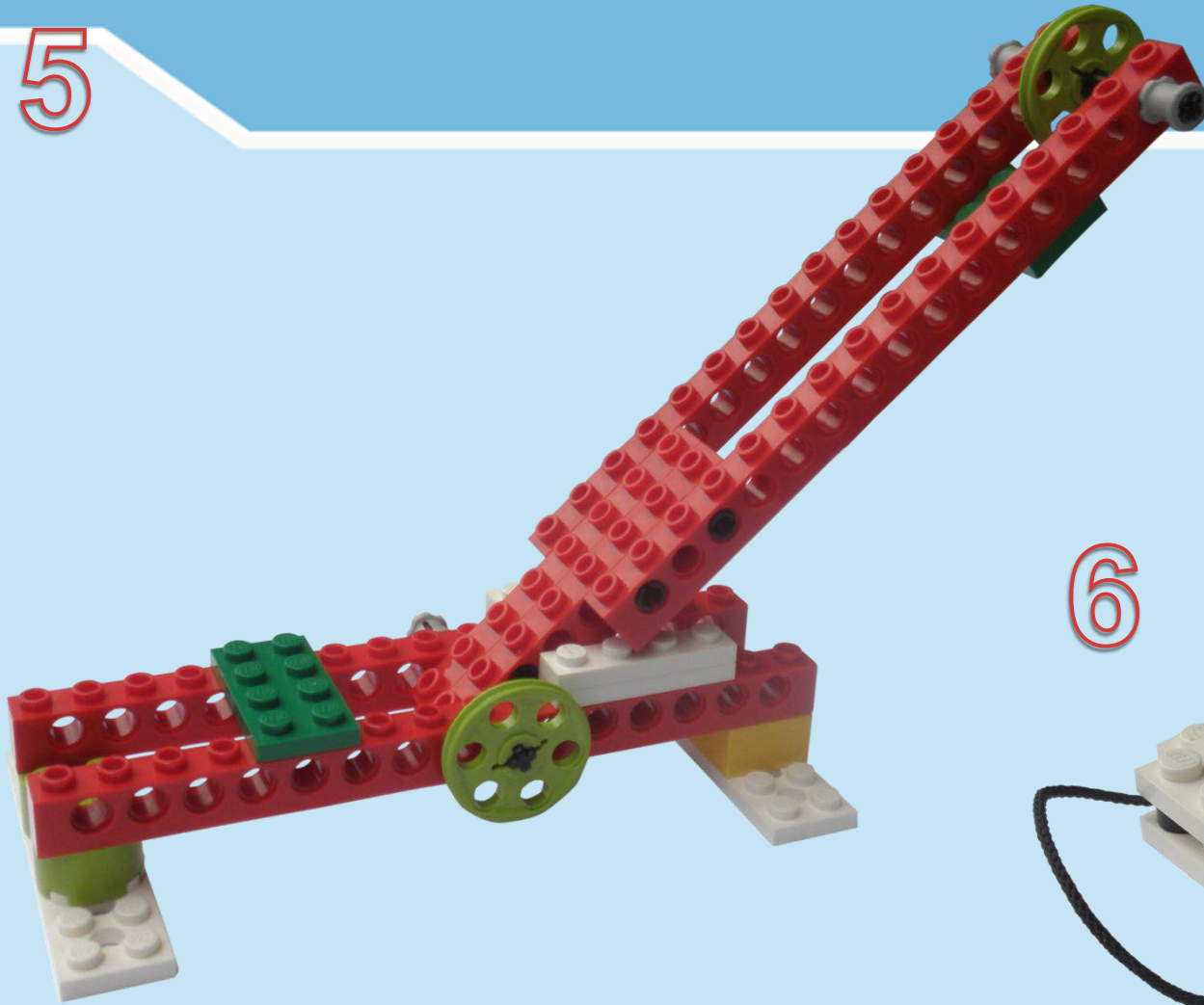

6

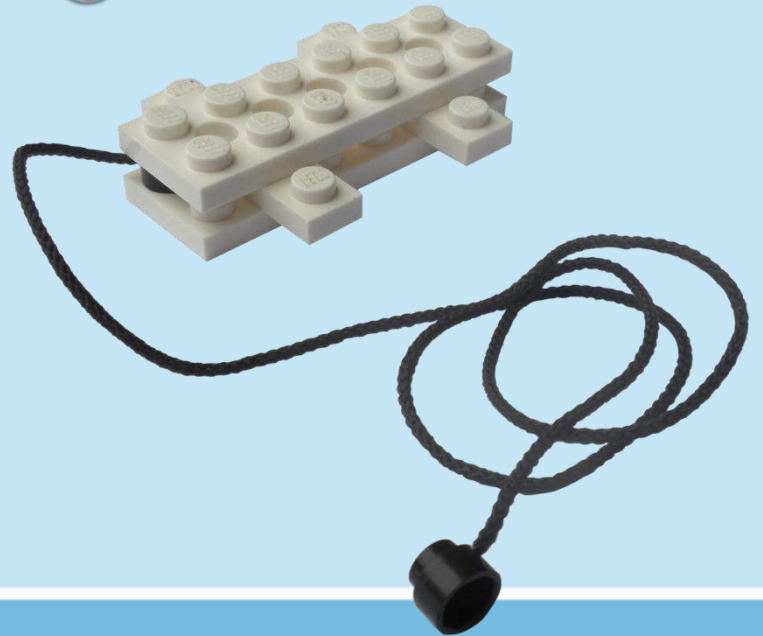

7

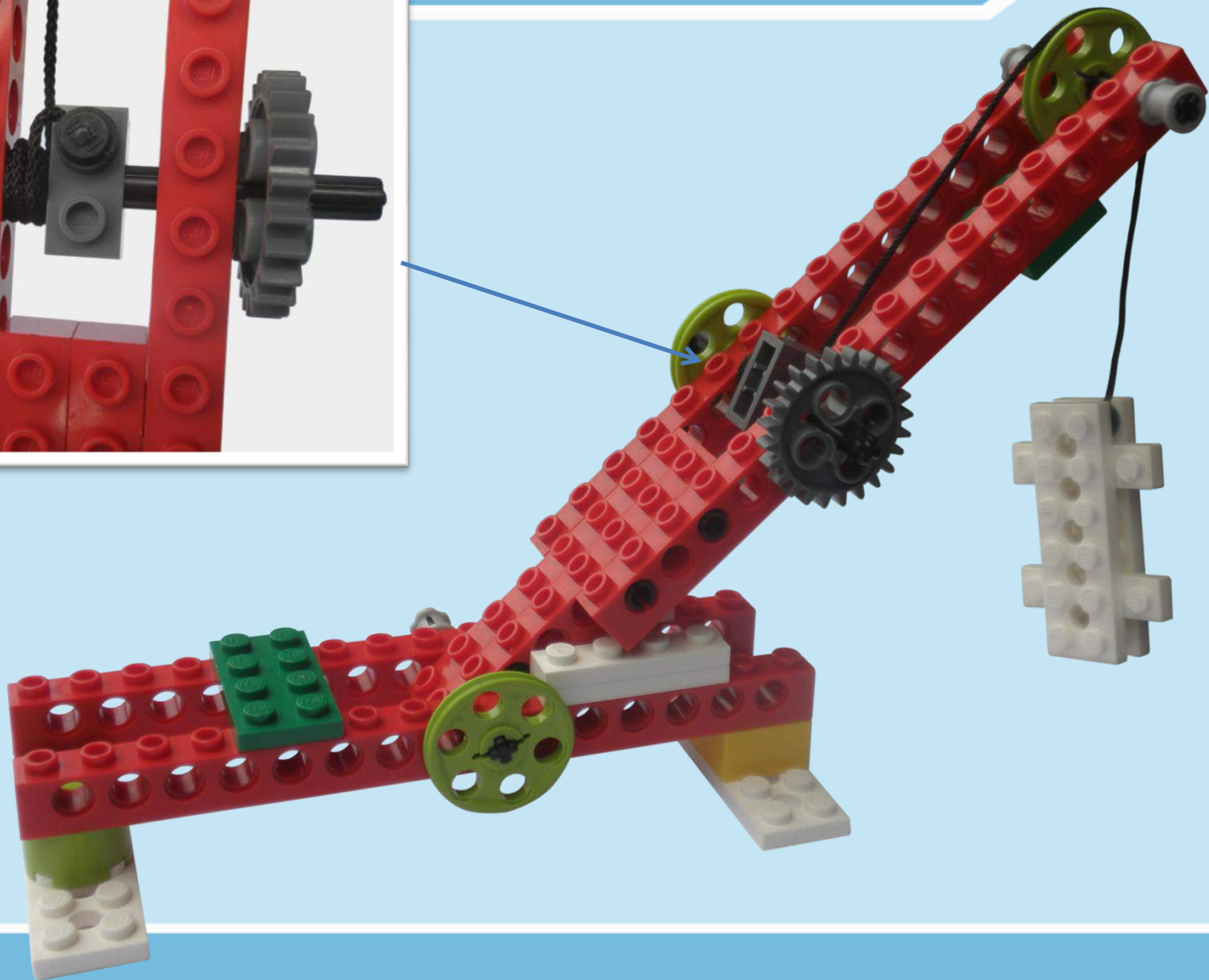
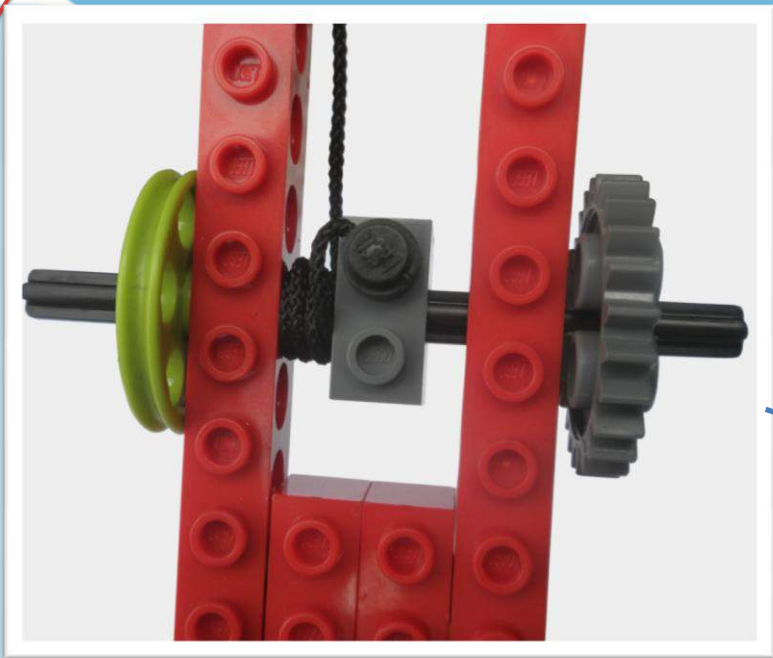

8

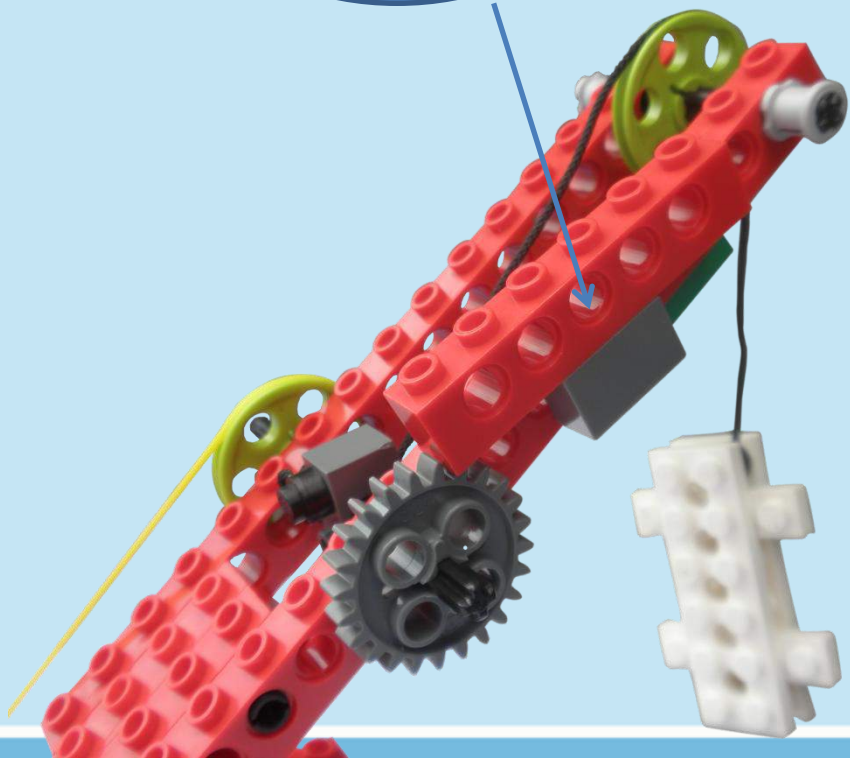
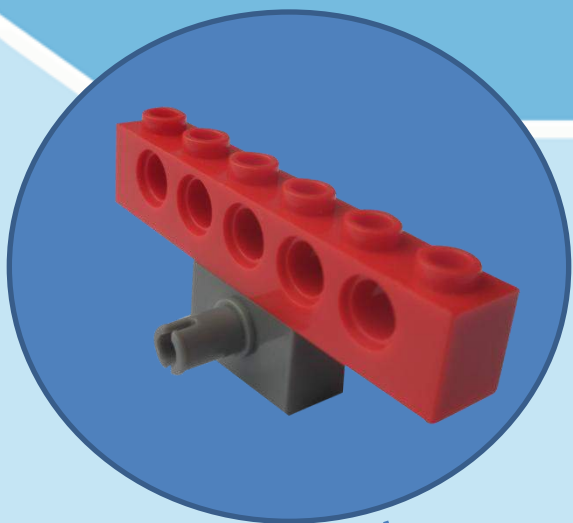

9

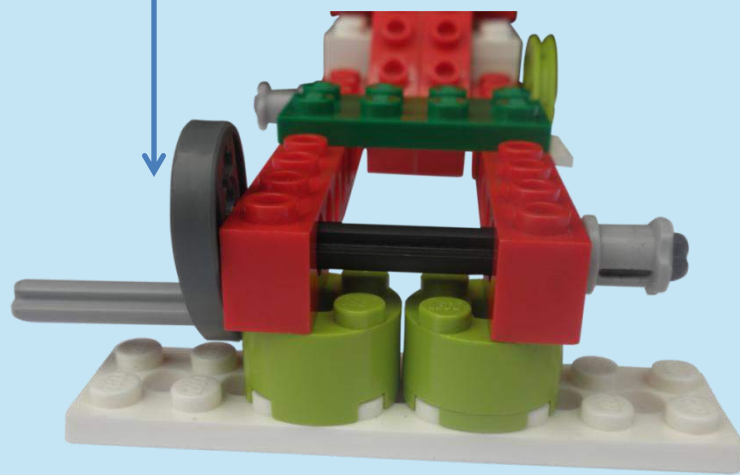
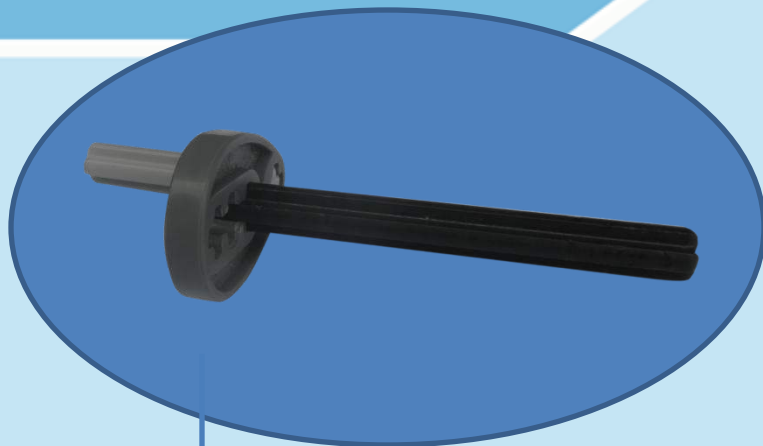

10

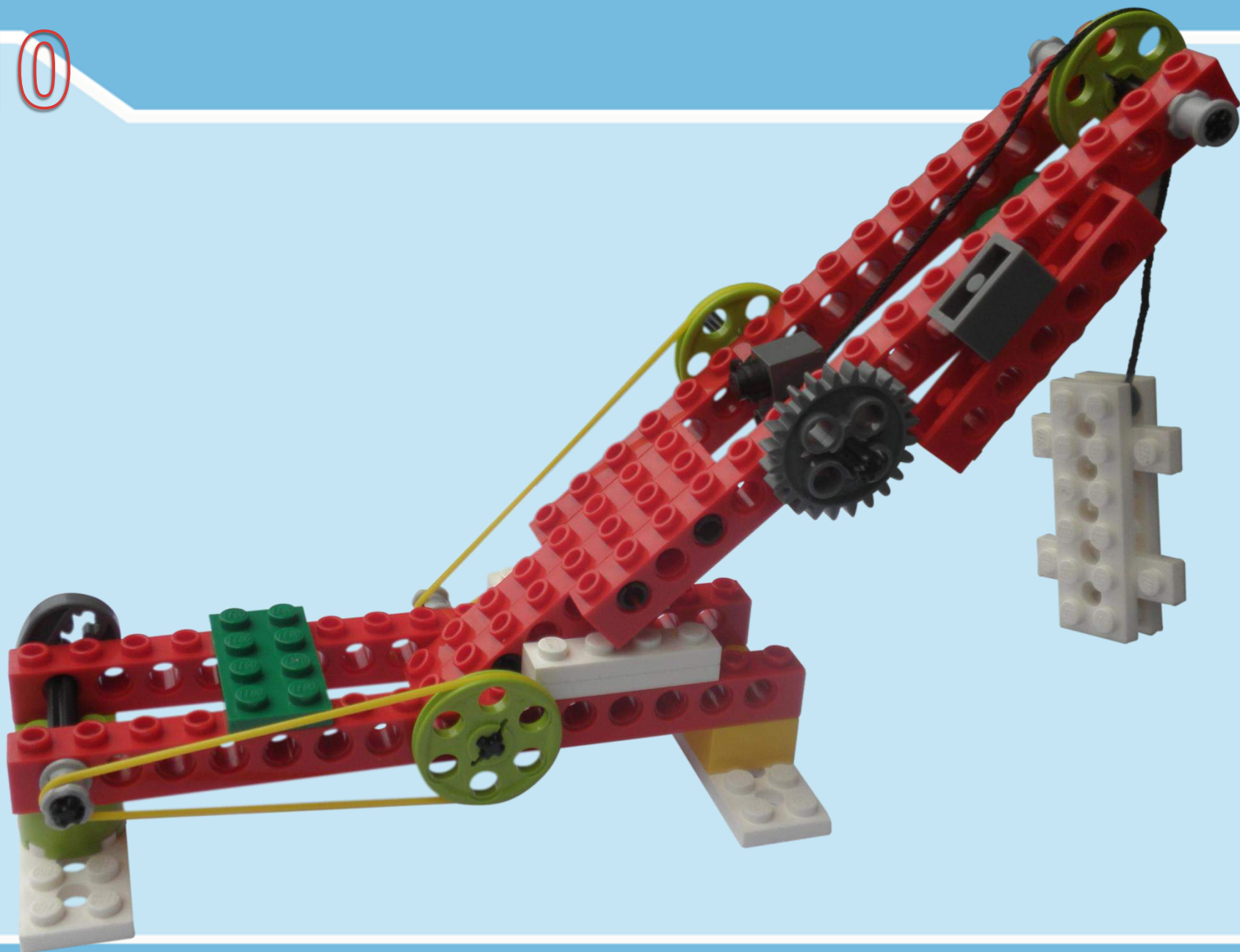

11

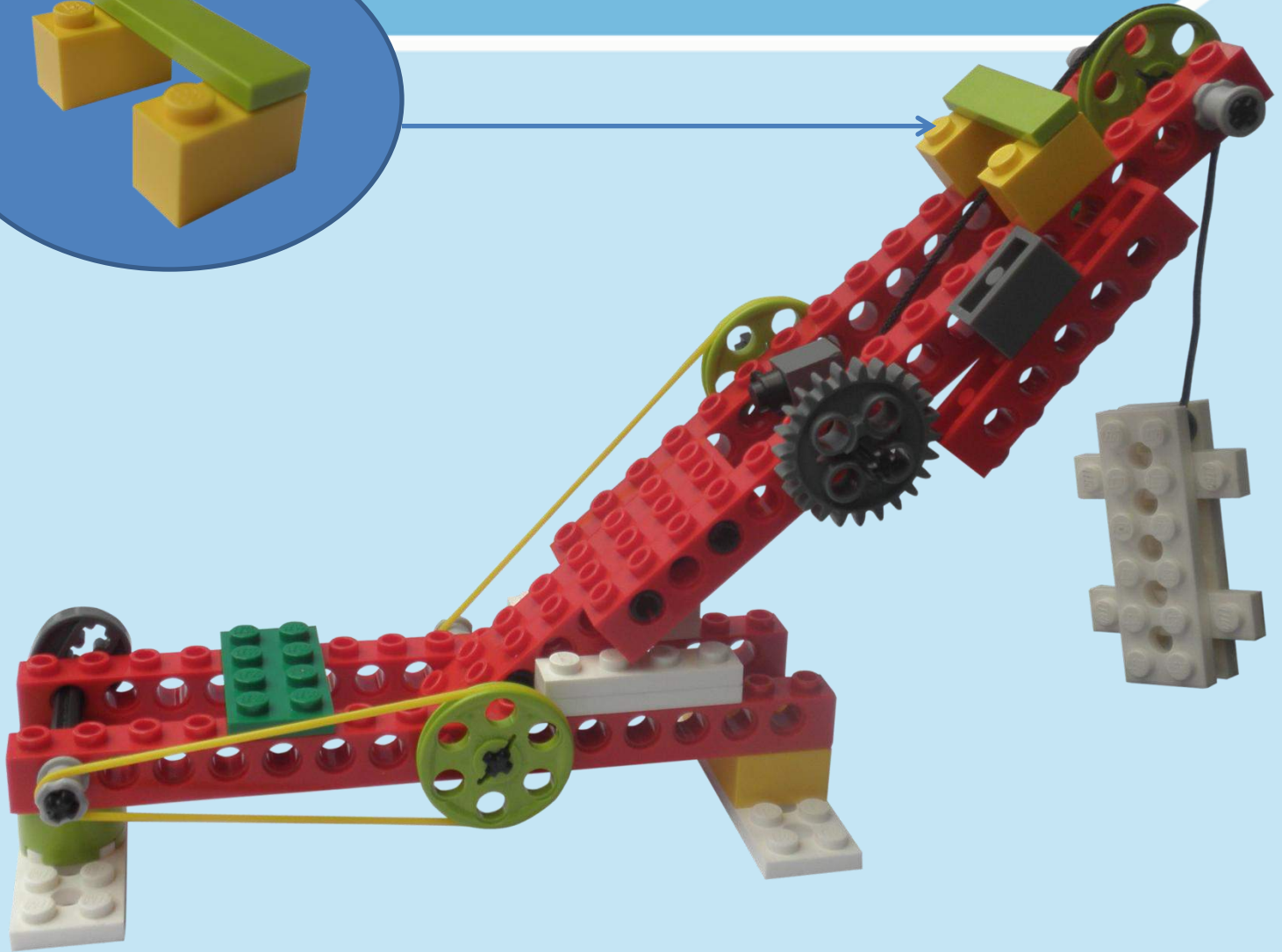
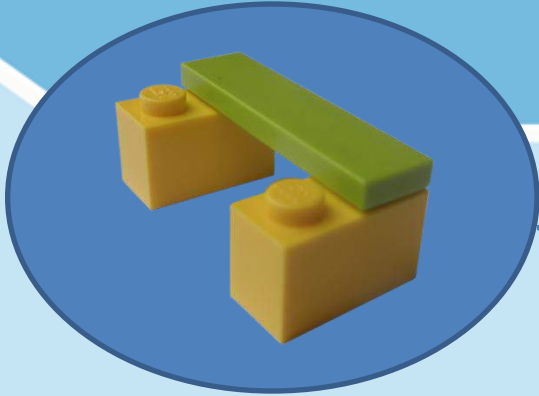

RUEDAS Y EJES



RUEDAS Y EJES

- Es un disco circular con radios que ha sido diseñado para girar alrededor de un pequeño eje, que pasa por su centro.

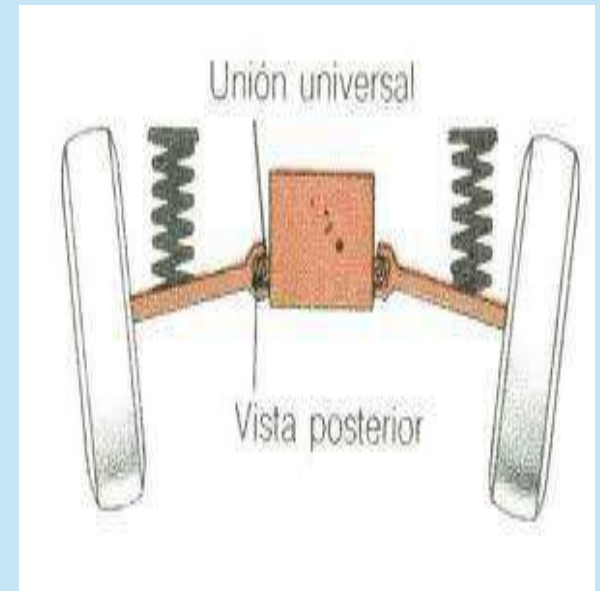

Modelos de principios de ruedas y ejes

PRINCIPIO I

Se necesita menos fuerza para empujar un objeto sobre ruedas que para deslizar un objeto sin ellas

Modelo 1: Deslizando

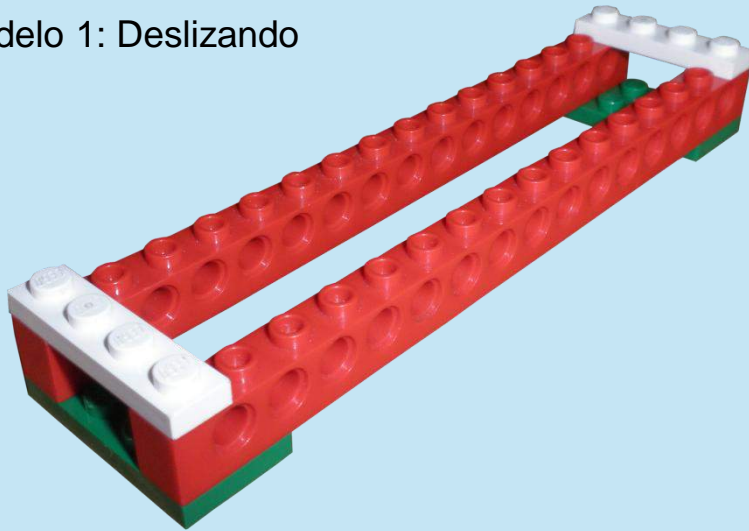

Modelo 2: Deslizando

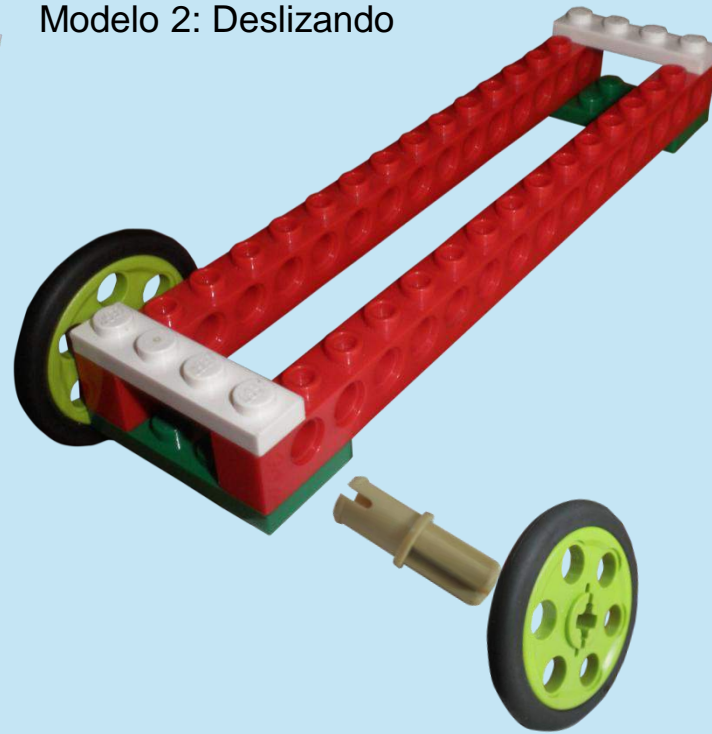

PRINCIPIO II

Las ruedas que están unidas por un eje basta deslizar una para que la otra también se mueva pero las ruedas que tienen distintos ejes, se mueven independientemente

Modelo 3: Descendiendo

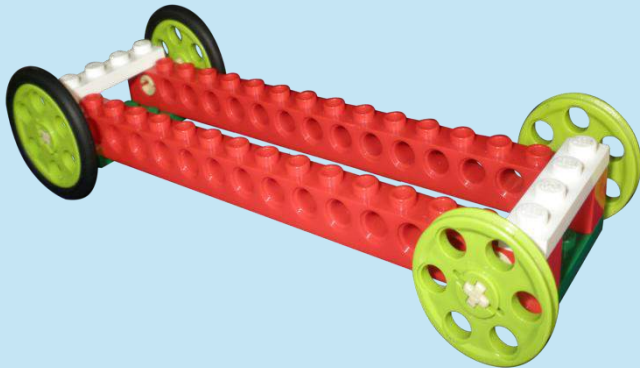

Modelo 4: Descendiendo



Modelo 5: Monoeje

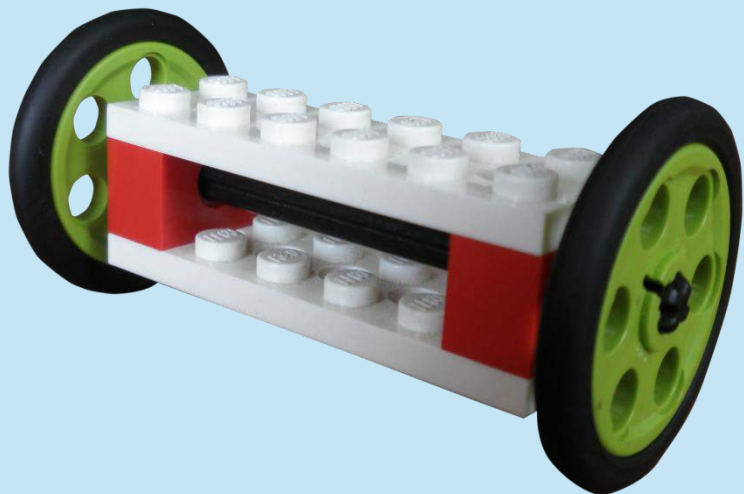

Modelo 6: Ejes separados



PRINCIPIO III

Las ruedas se pueden usar como rodillos para reducir la fricción (fuerza de rozamiento)

Modelo 7: Monoeje

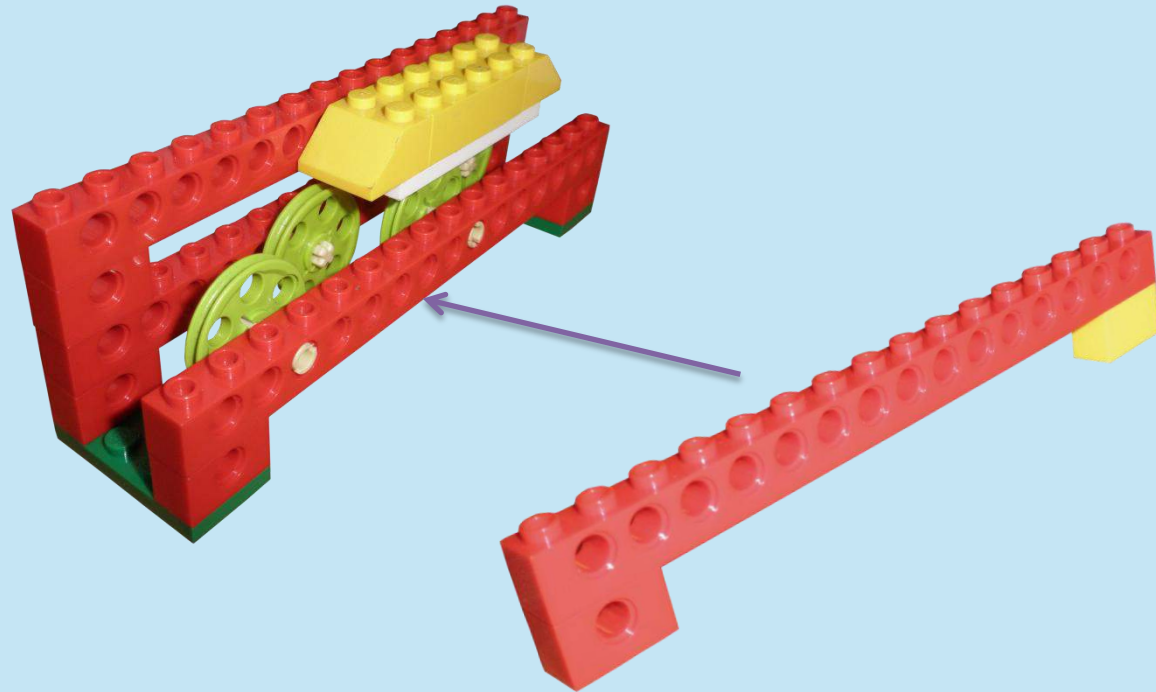

PRINCIPIO IV

Una rueda hacer girar un eje que a su vez enrolla o desenrolla una cuerda para elevar o bajar cosas pesadas

Modelo 8: Manija de torno de cuerda

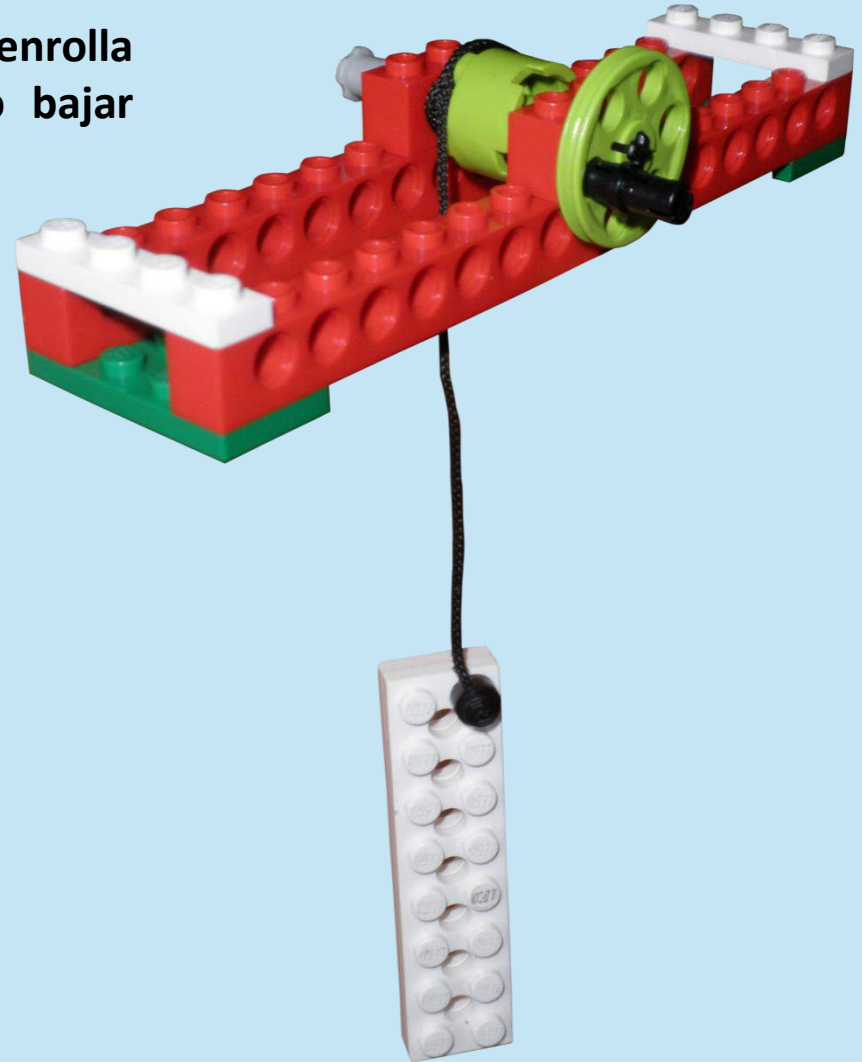

Auto Lego



1

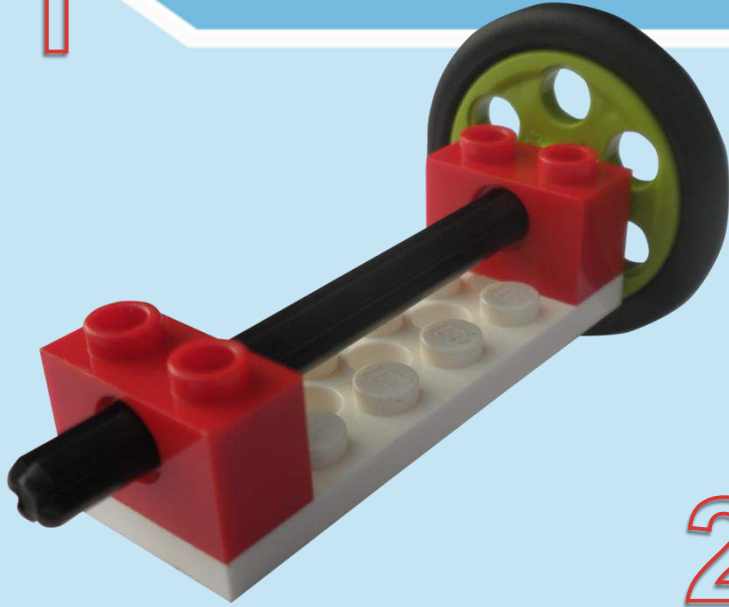

2

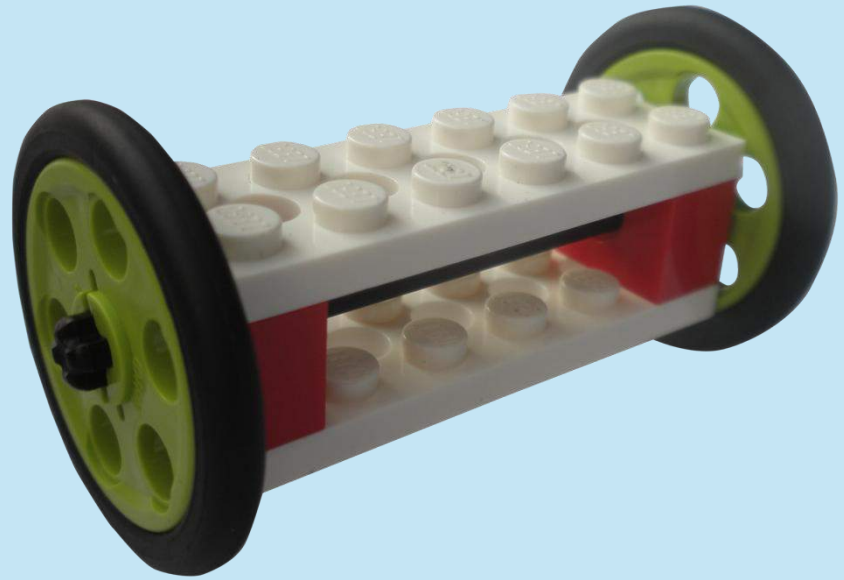

3

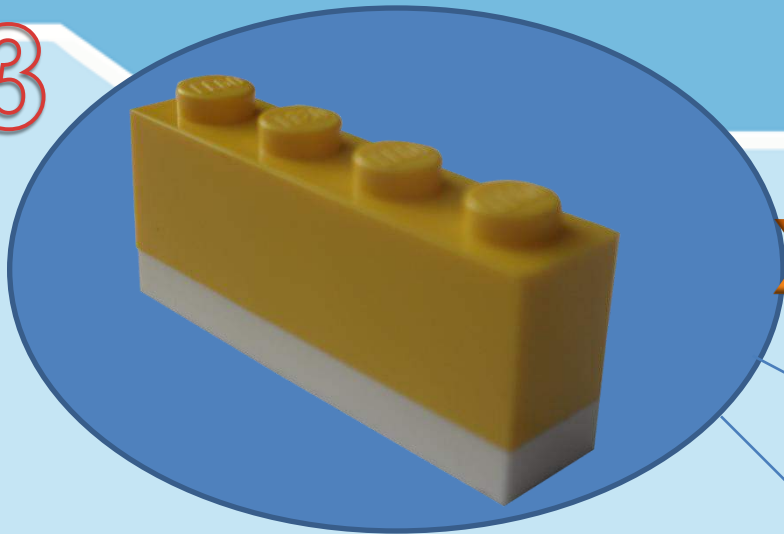

x2

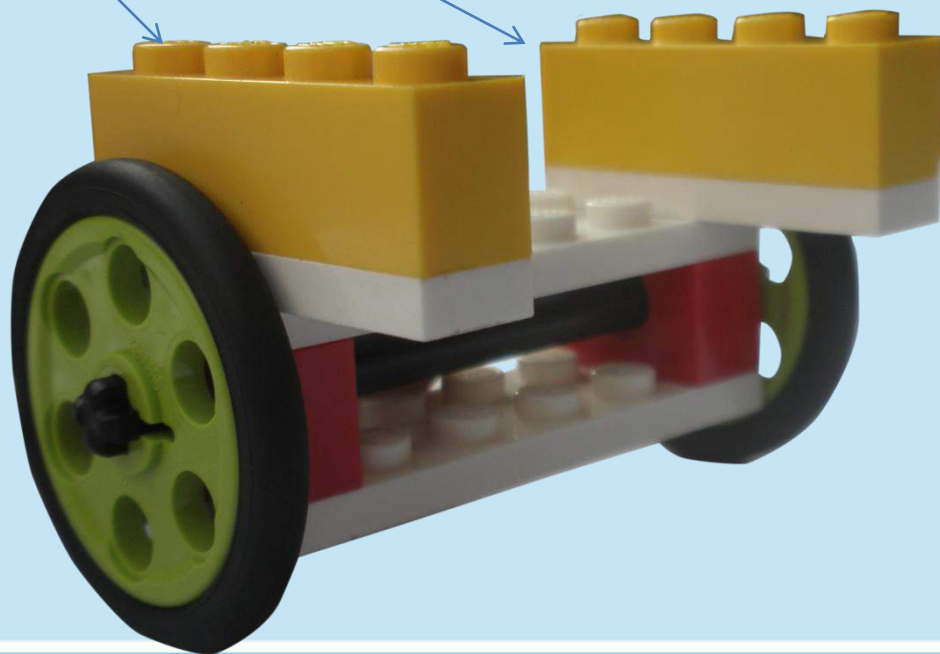

4

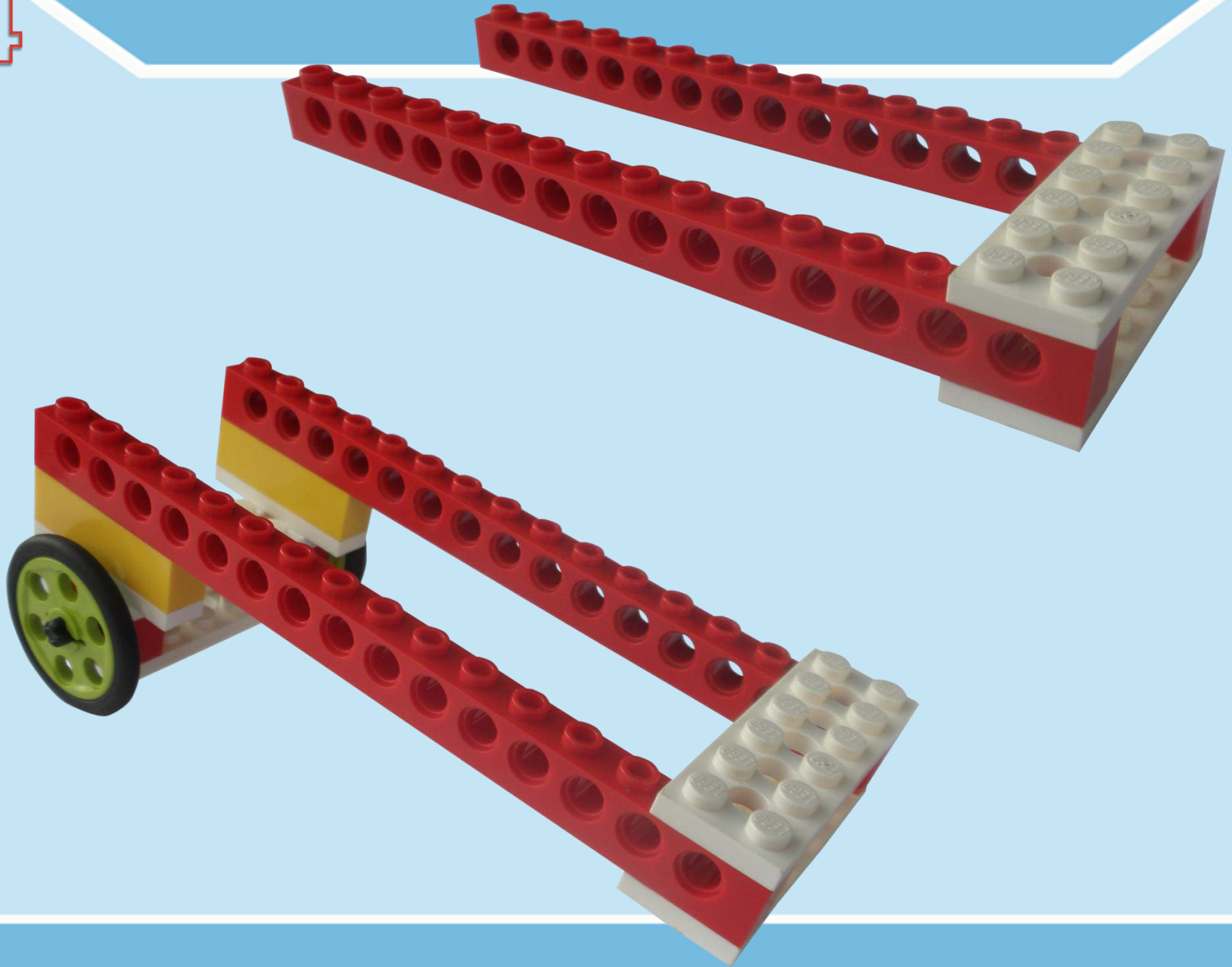

5

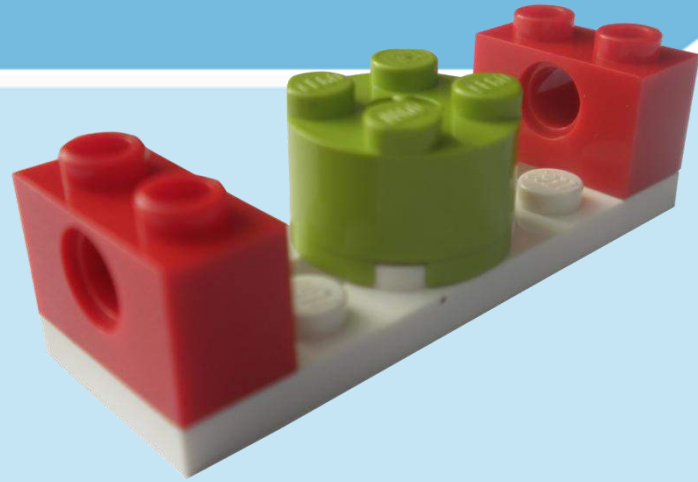

x2

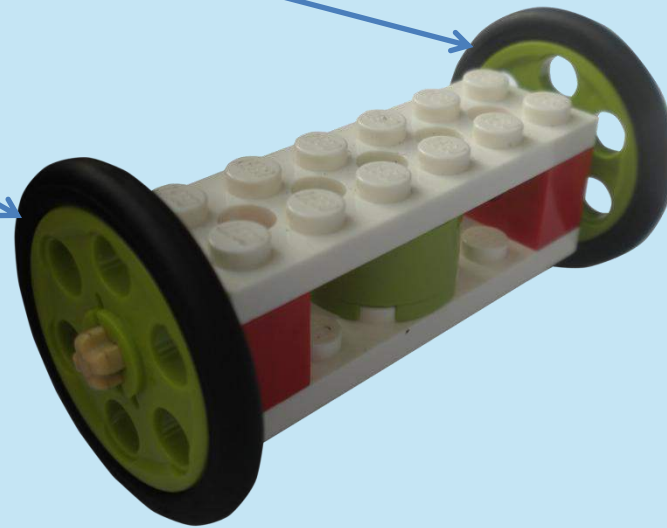

6

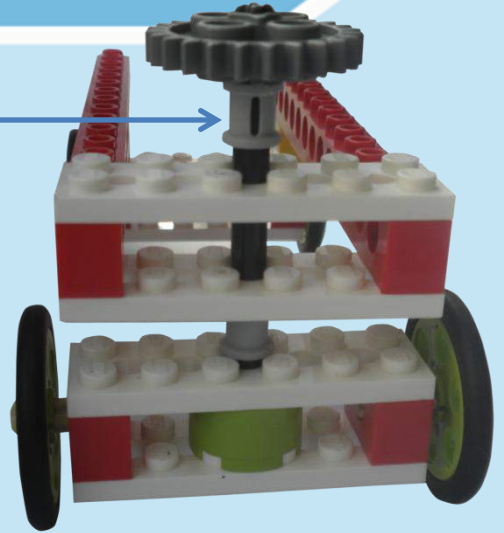
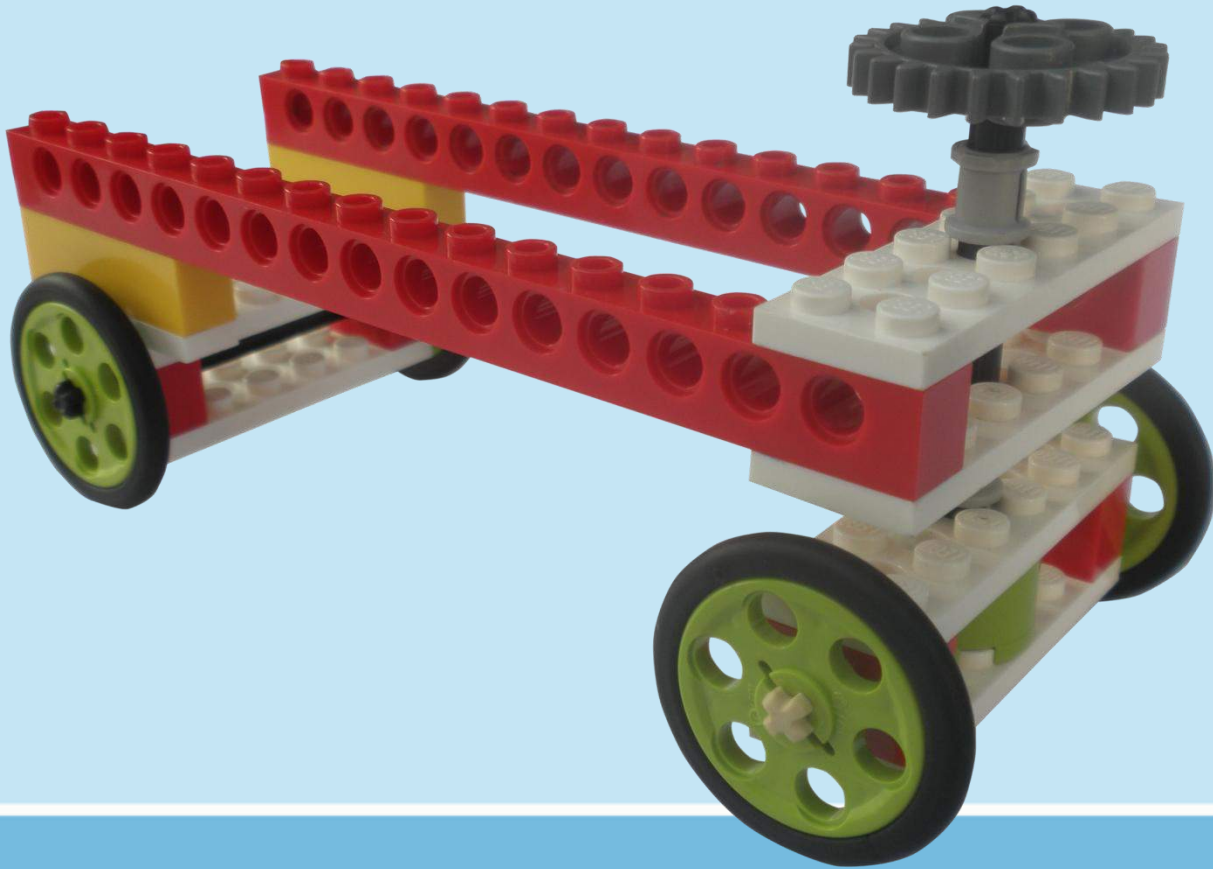
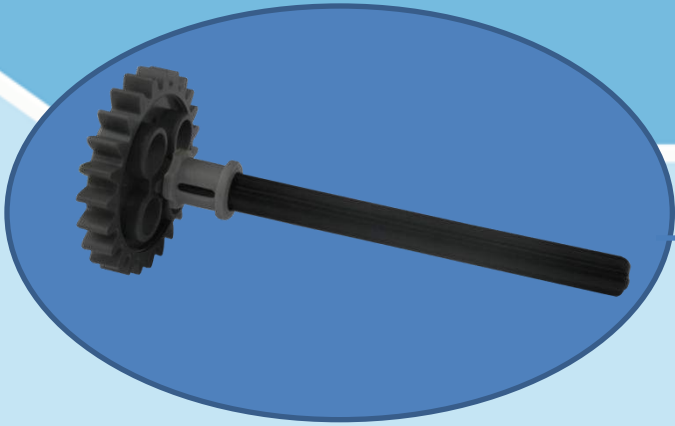

7

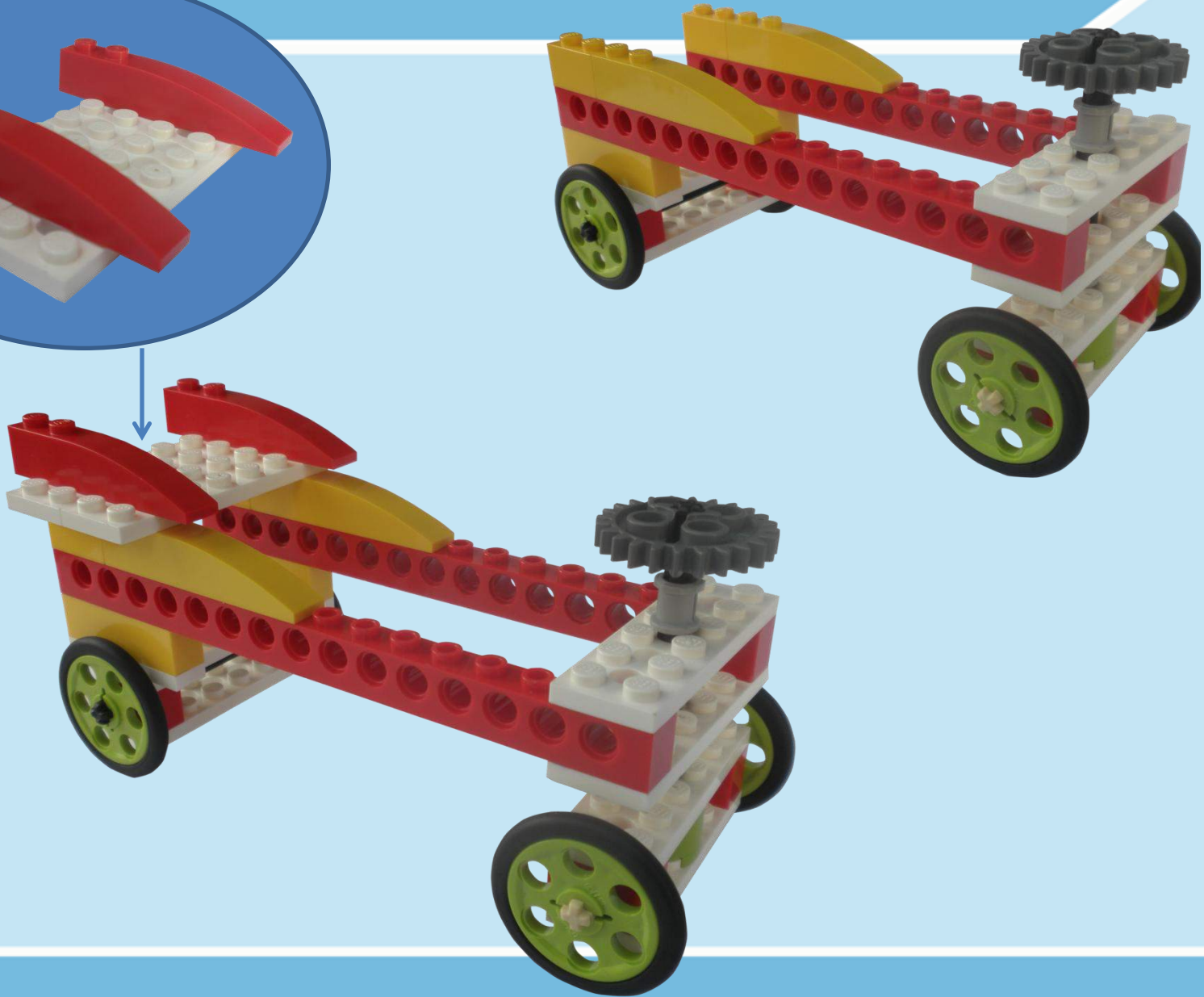
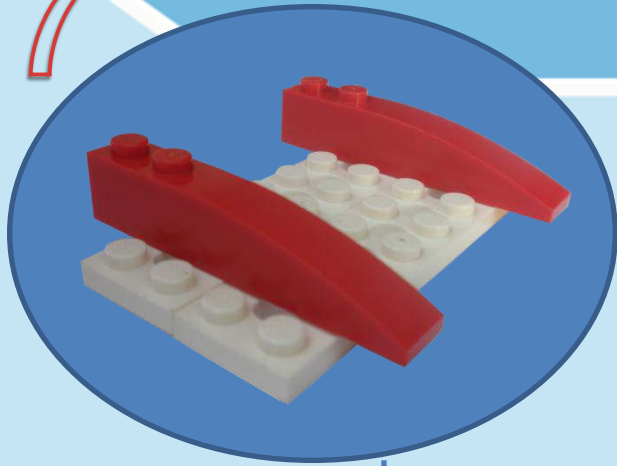

8



ENGRANAJES



ENGRANAJES

- **El engranaje es una modificación de la rueda y el eje. Tiene dientes alrededor. Es decir, es una rueda dentada que encaja exactamente con otra rueda dentada. Lo encontramos en:**
- **Las bicicletas**
- **Los autos**
- **El reloj**
- **Licuadaora**



Sistema de engranajes.



1

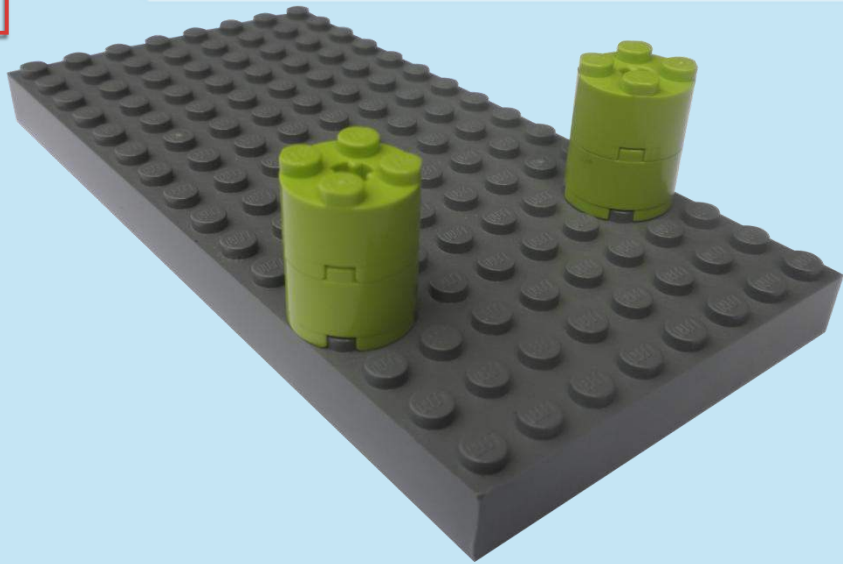

2

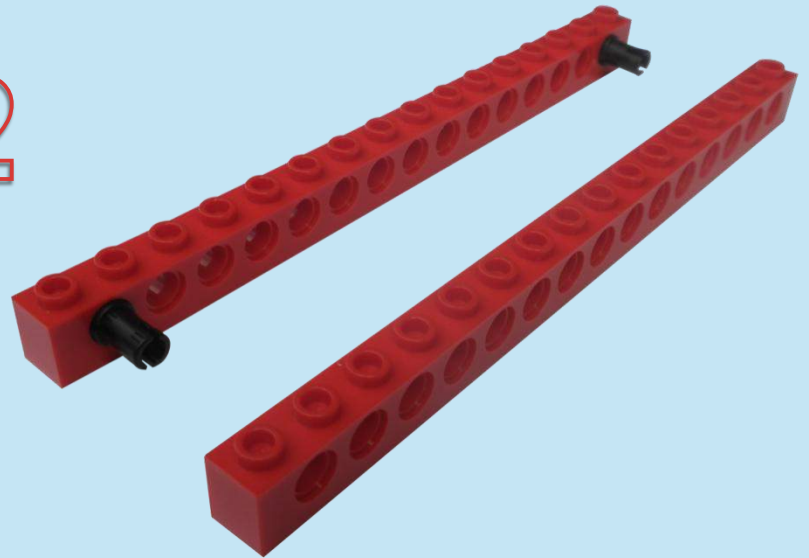

3

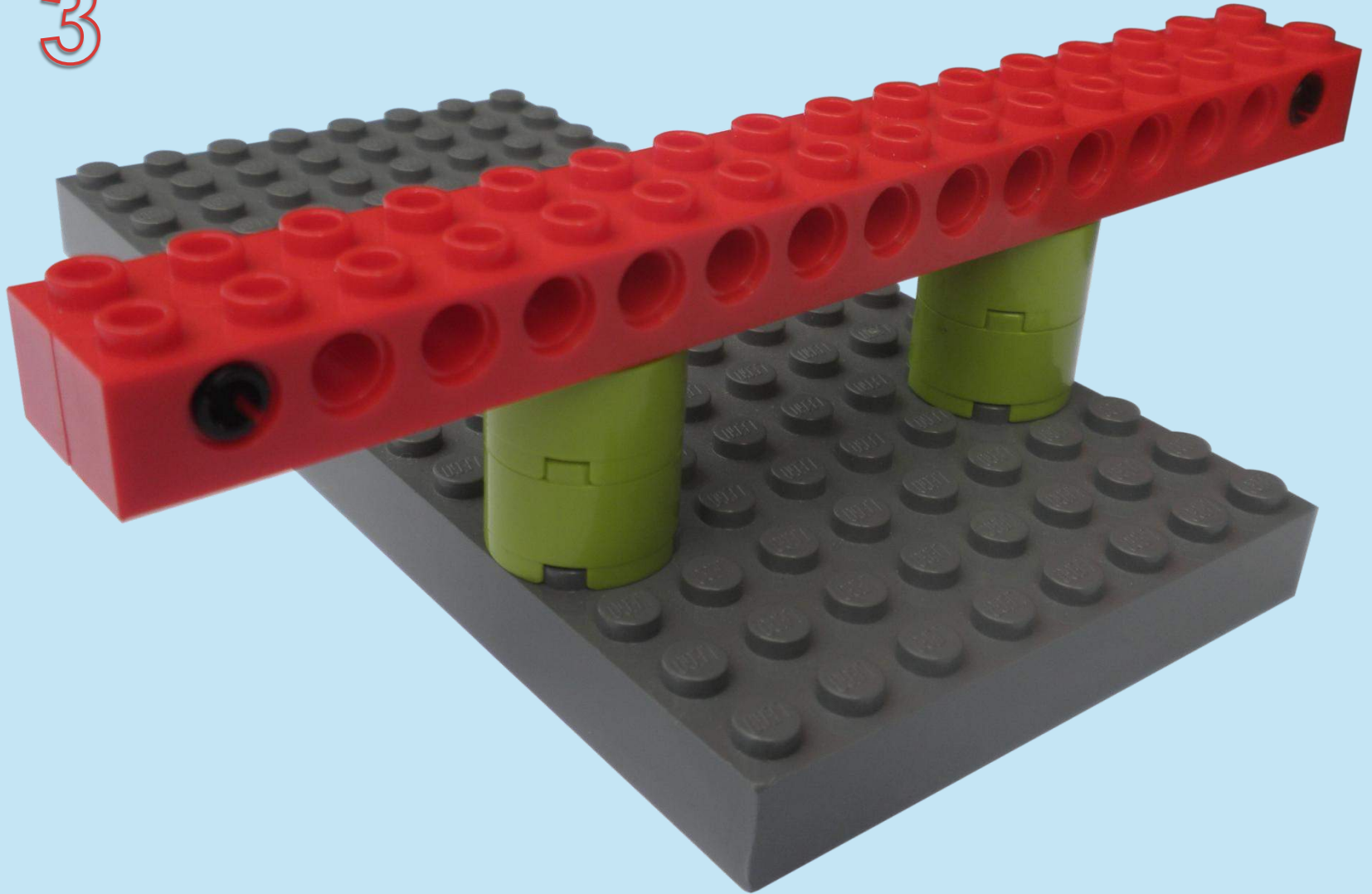

● Principio I: Dirección de rotación

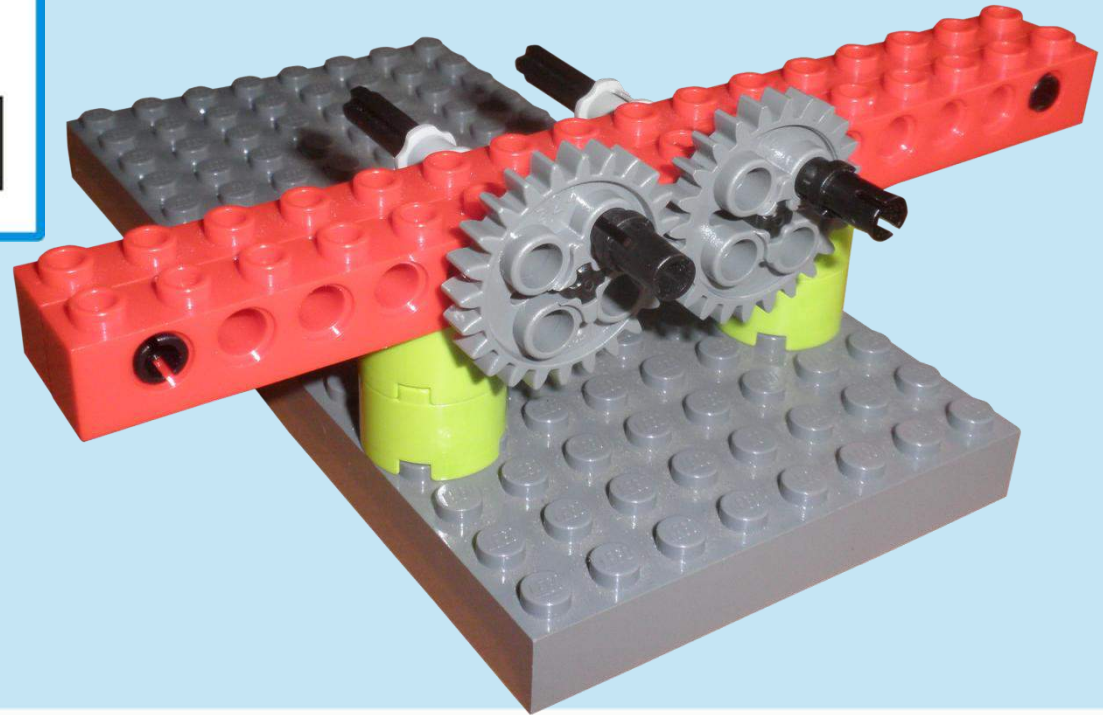
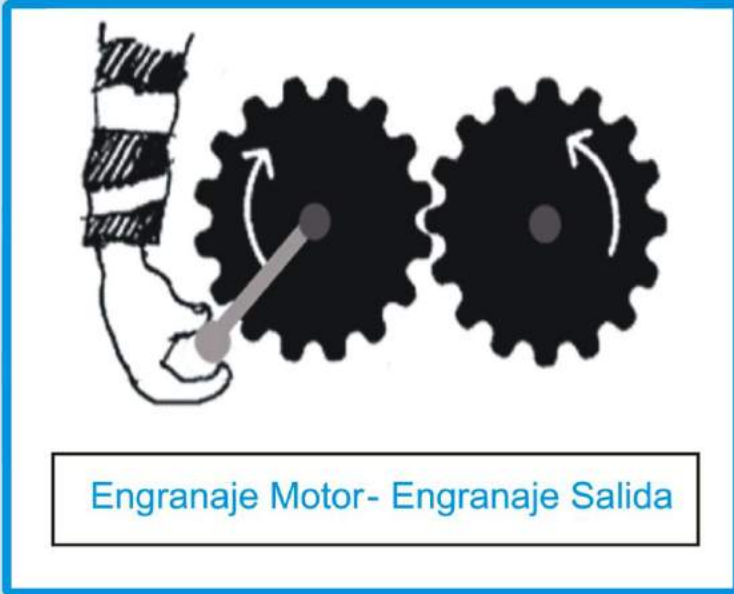

● Principio II: Aumento de la velocidad

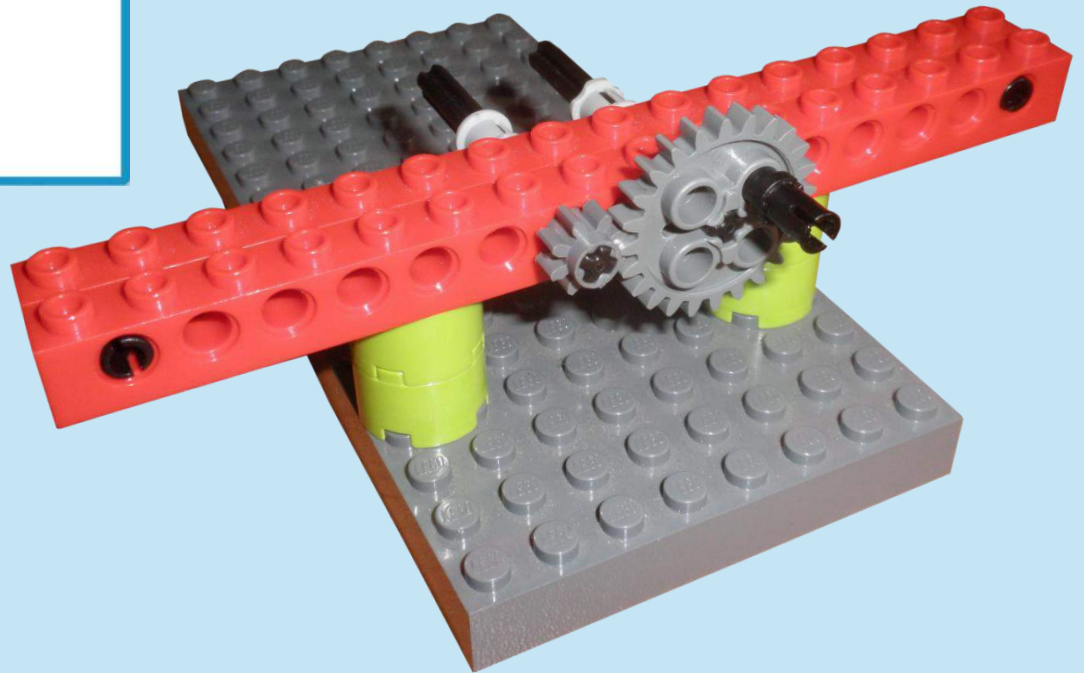
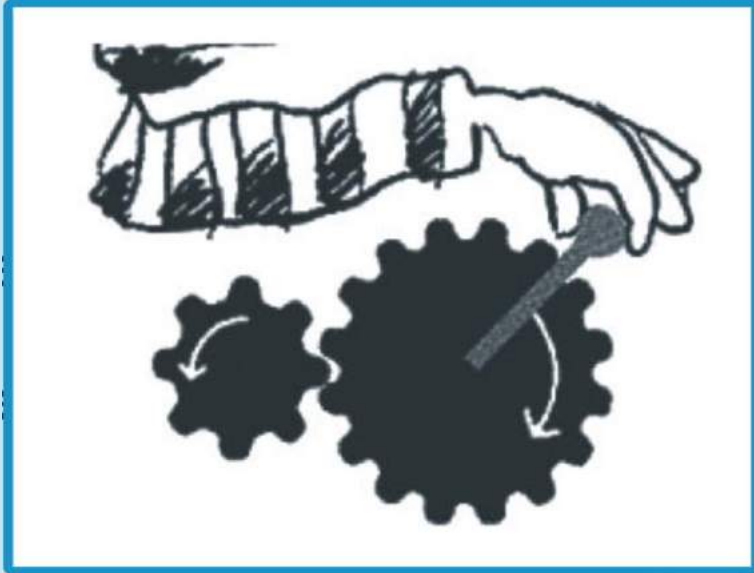

● Principio III: Reducción de velocidad

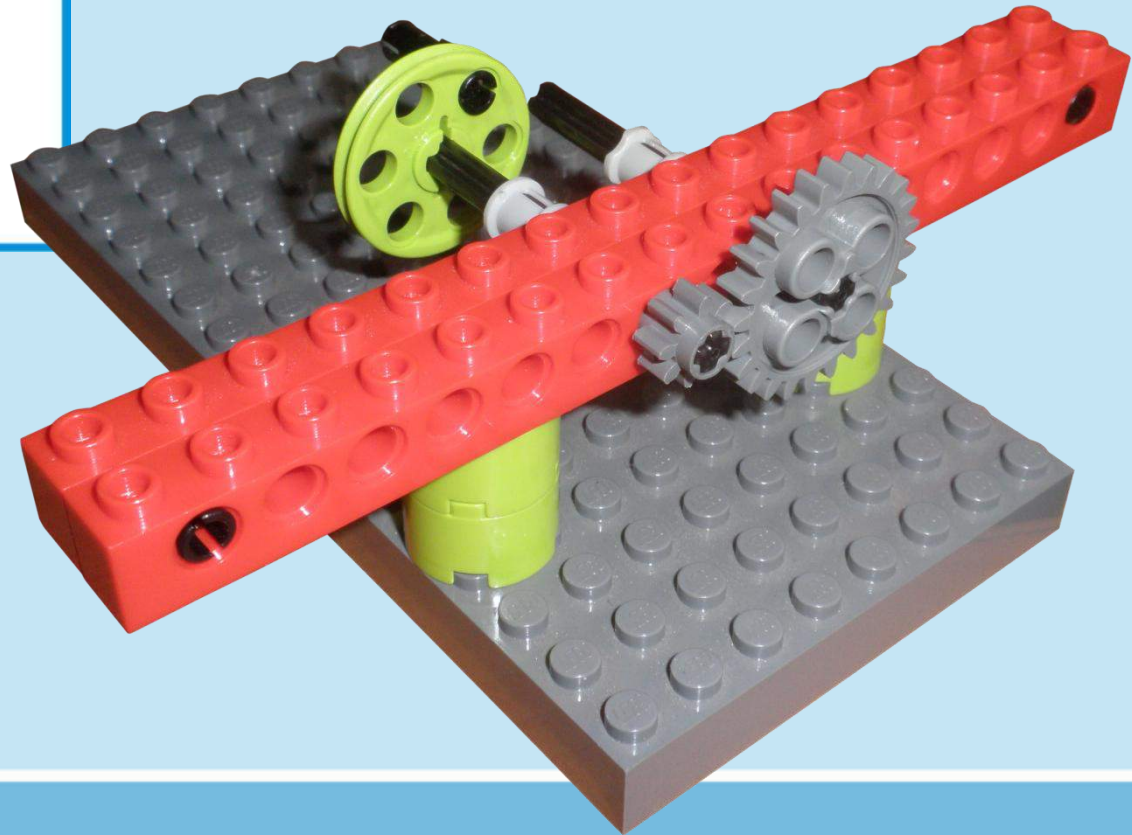
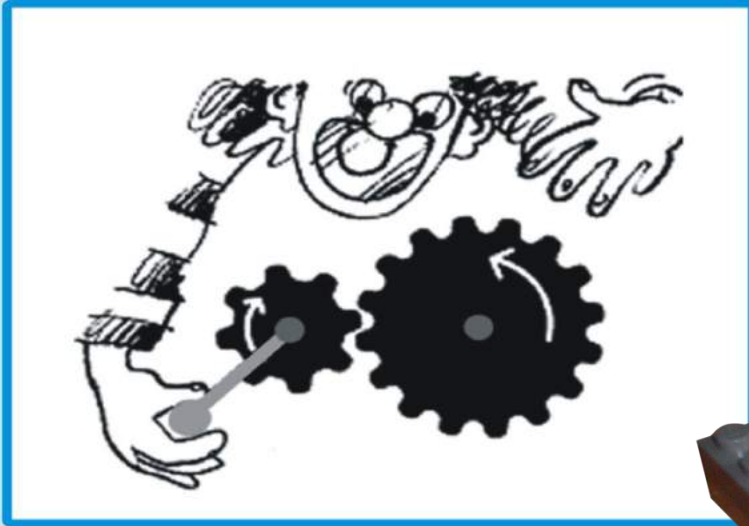

● Principio IV: Cambiar la dirección de rotación

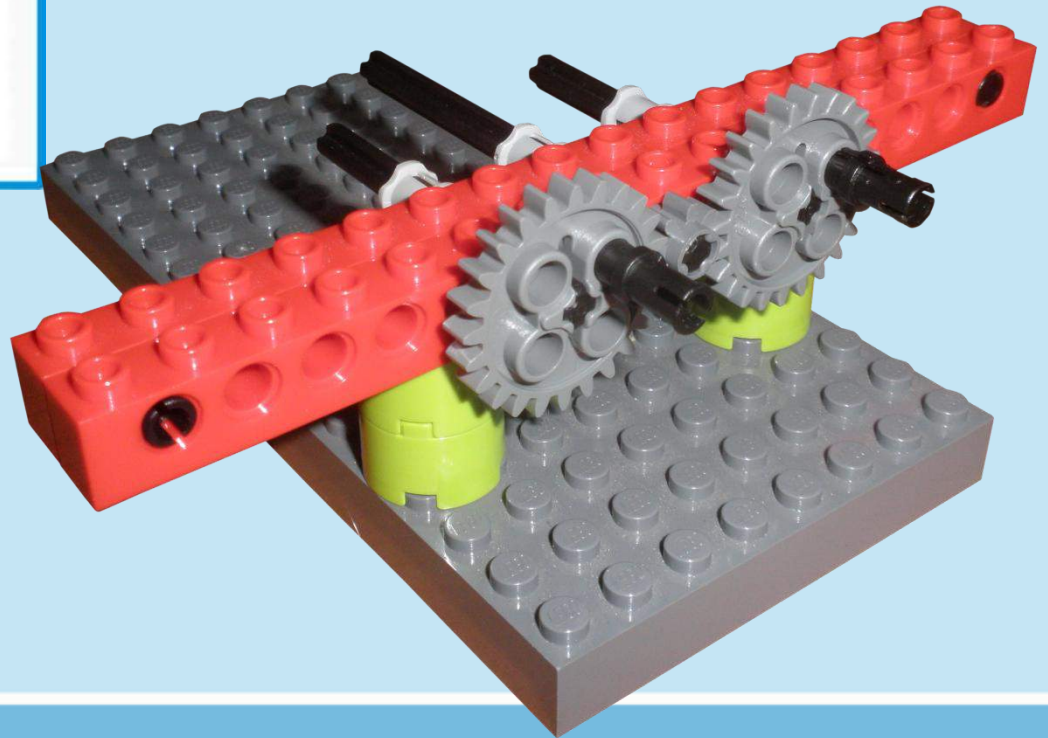
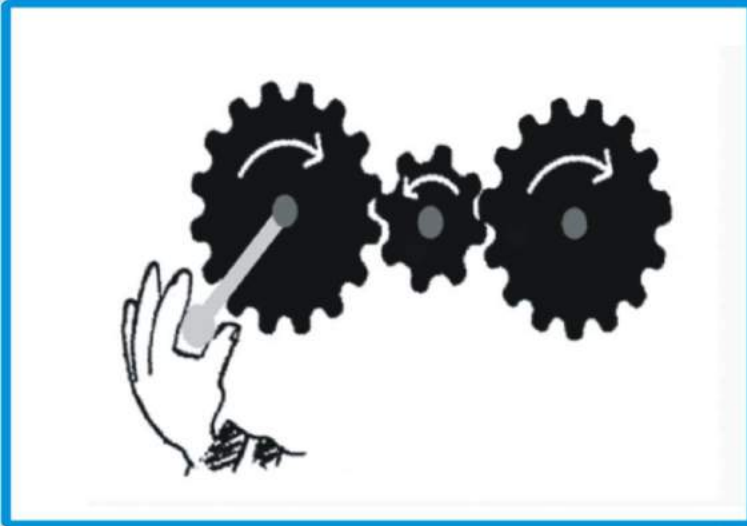

● Principio V: Cambiar la dirección de movimiento

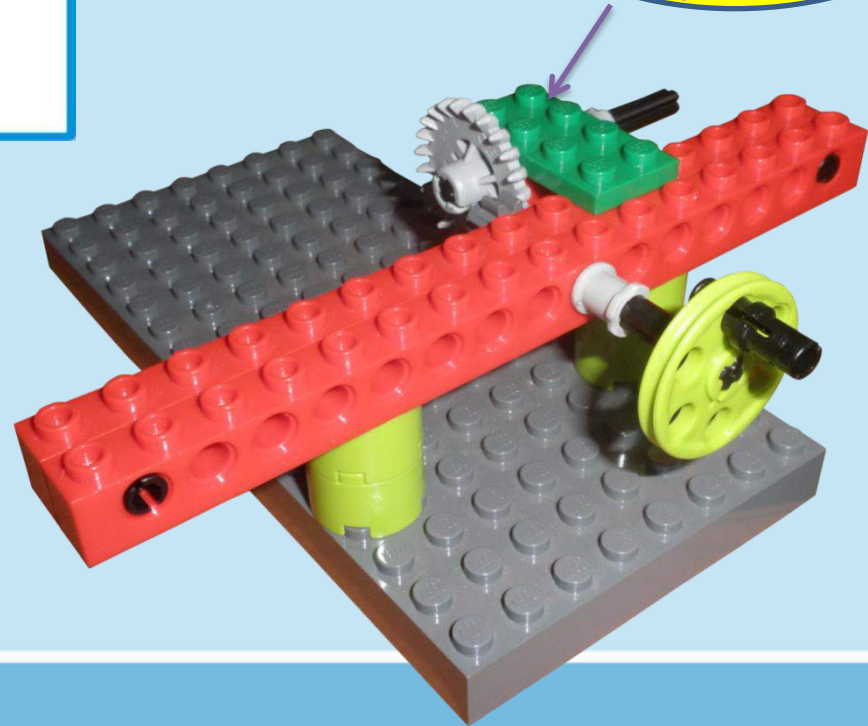
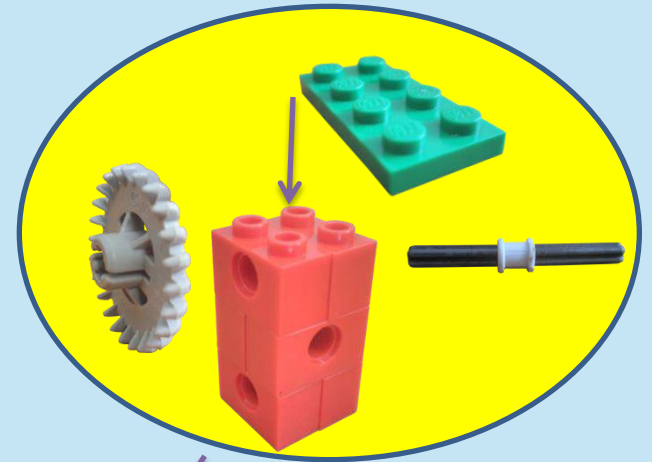
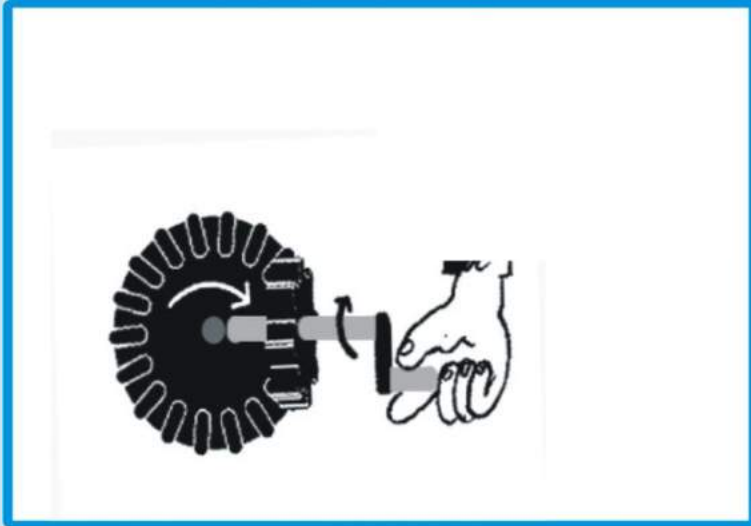

● Principio VI: Potencia y velocidad

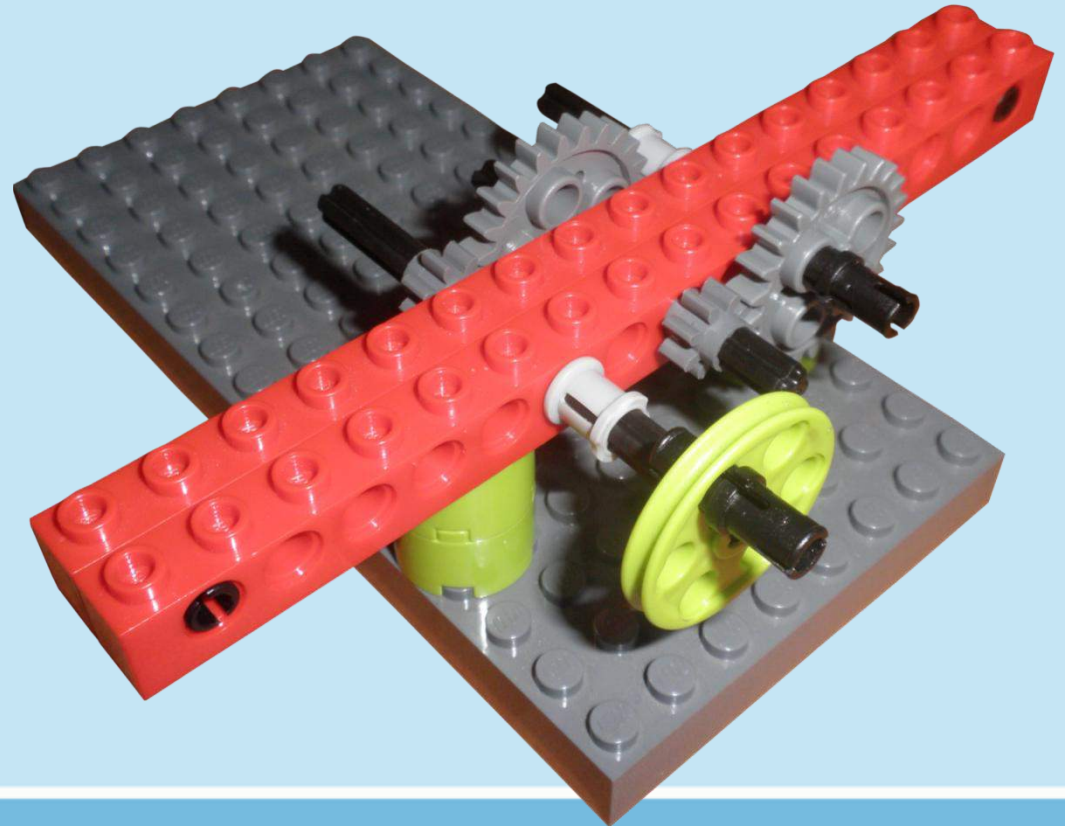
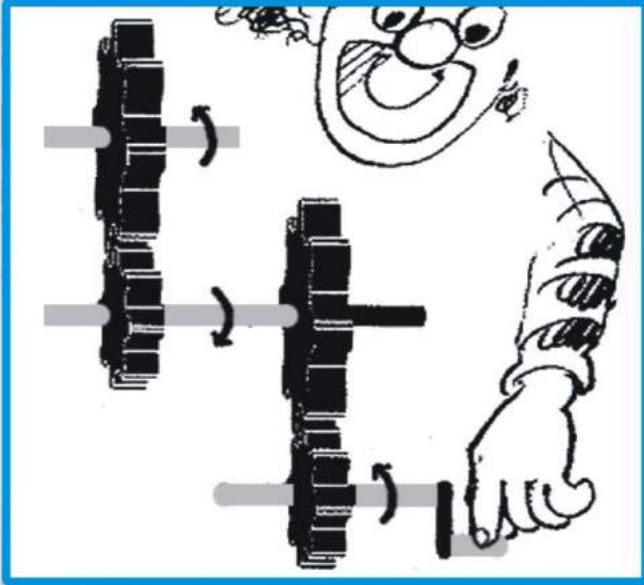

SILLA VOLADORA LEGO



1

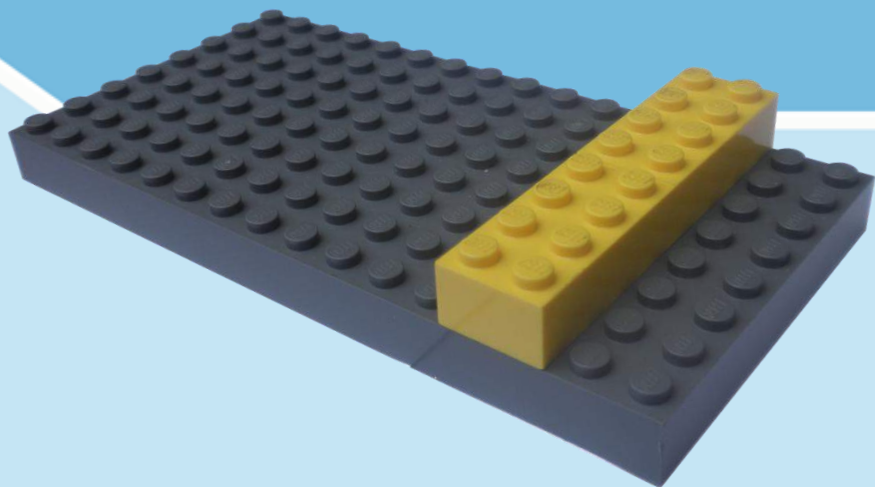

2

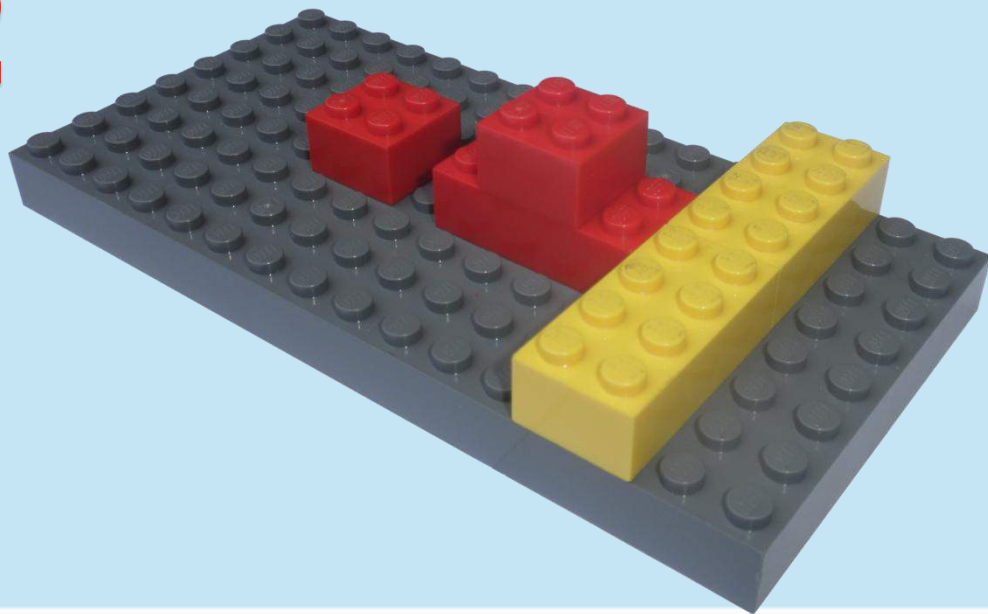

3

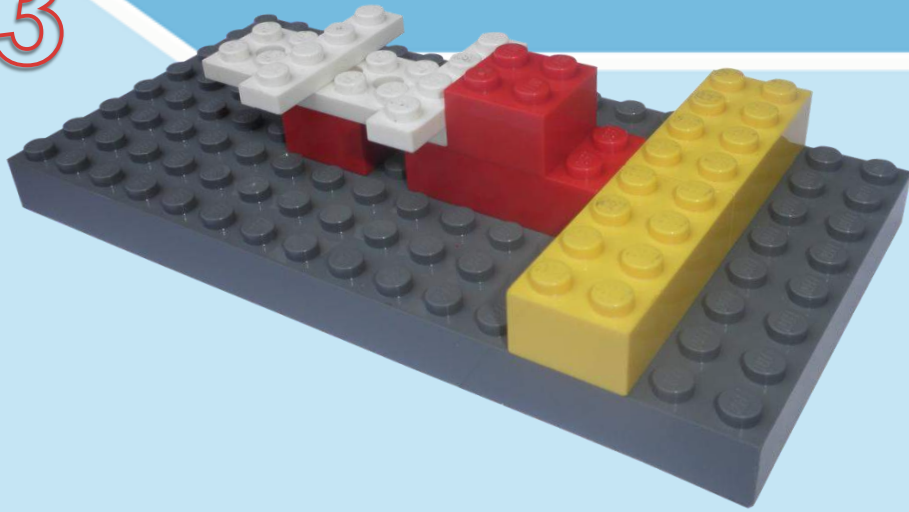

4

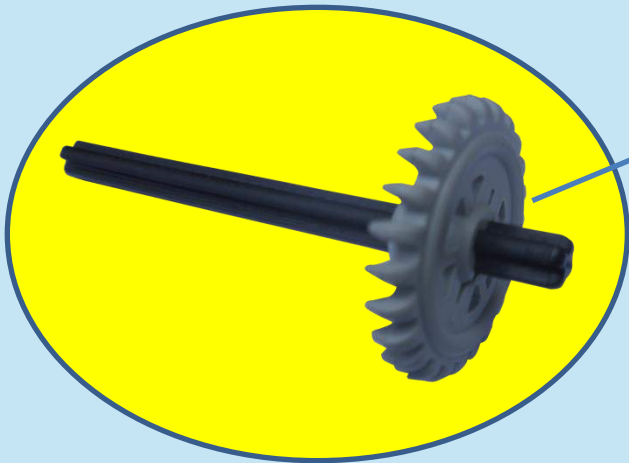
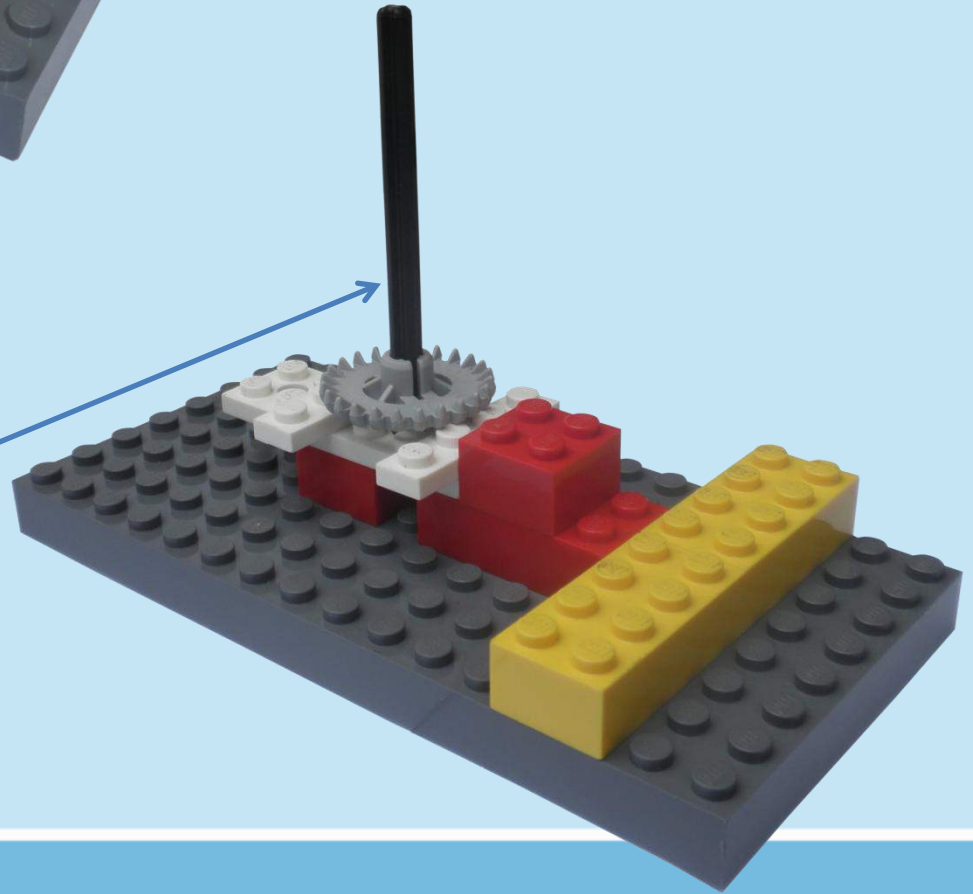

5

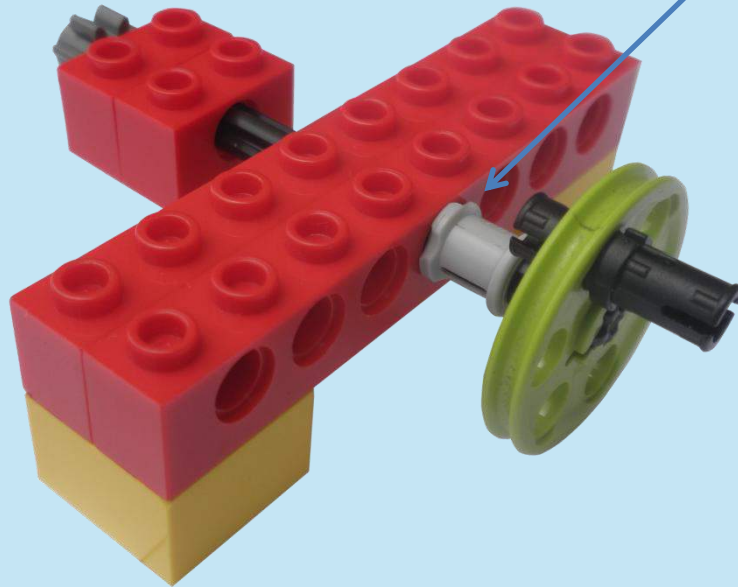
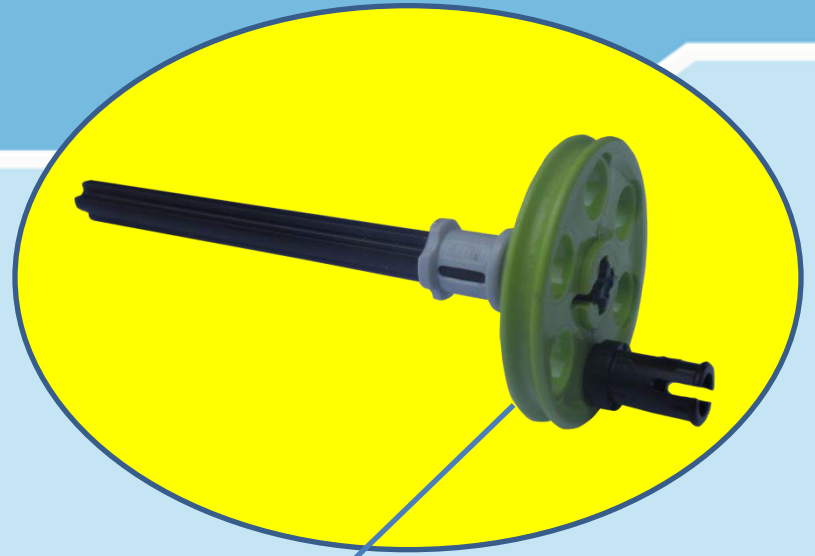
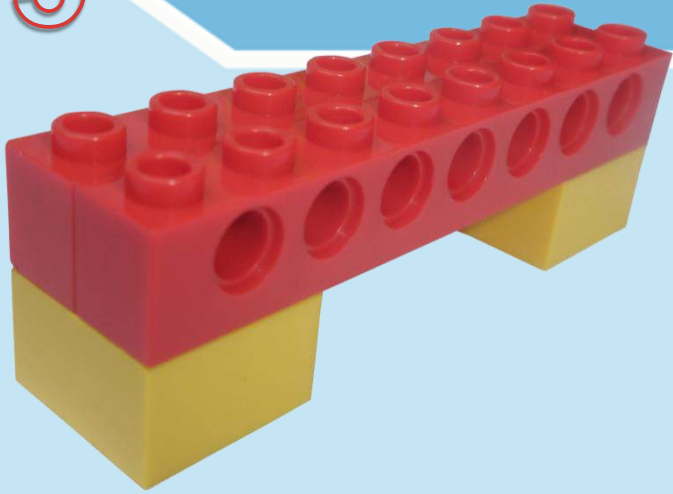

6

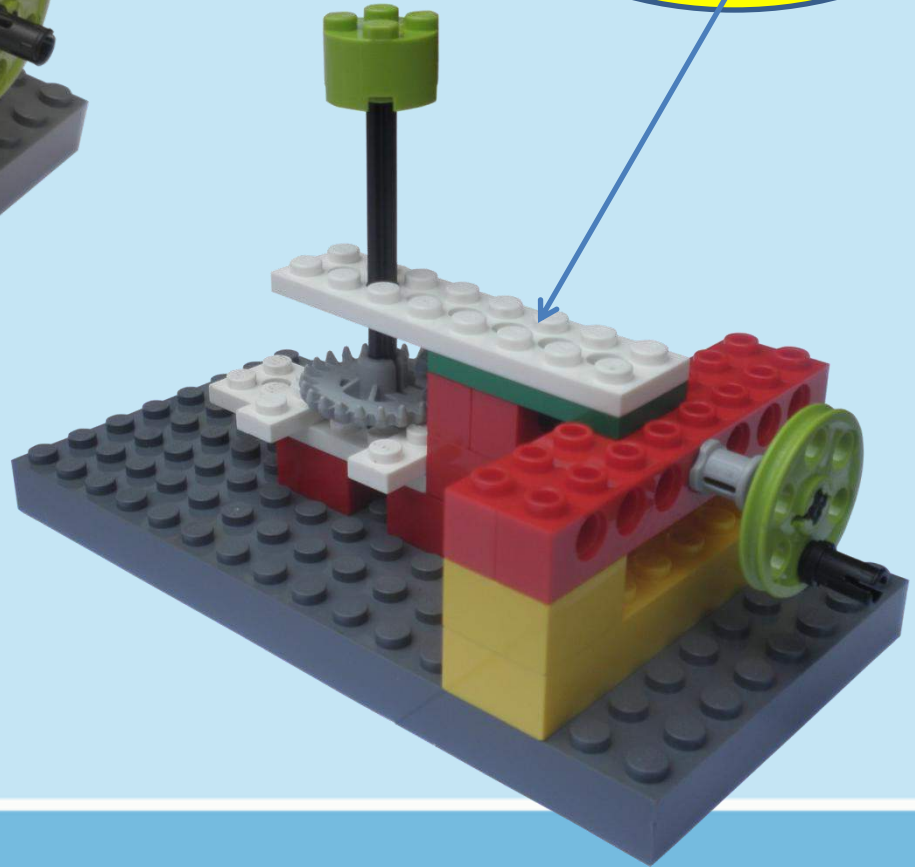
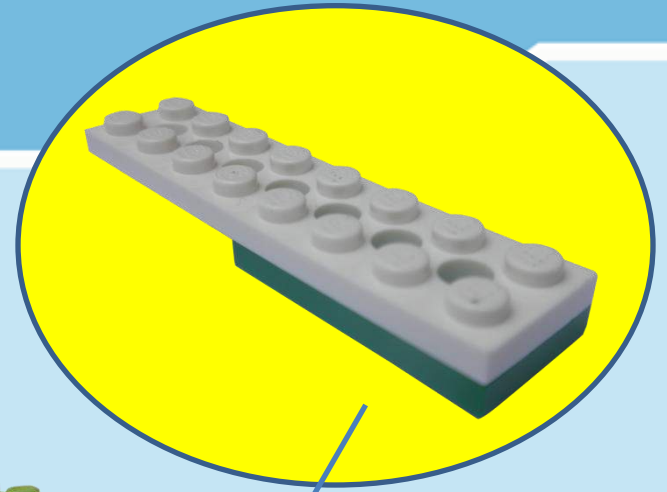
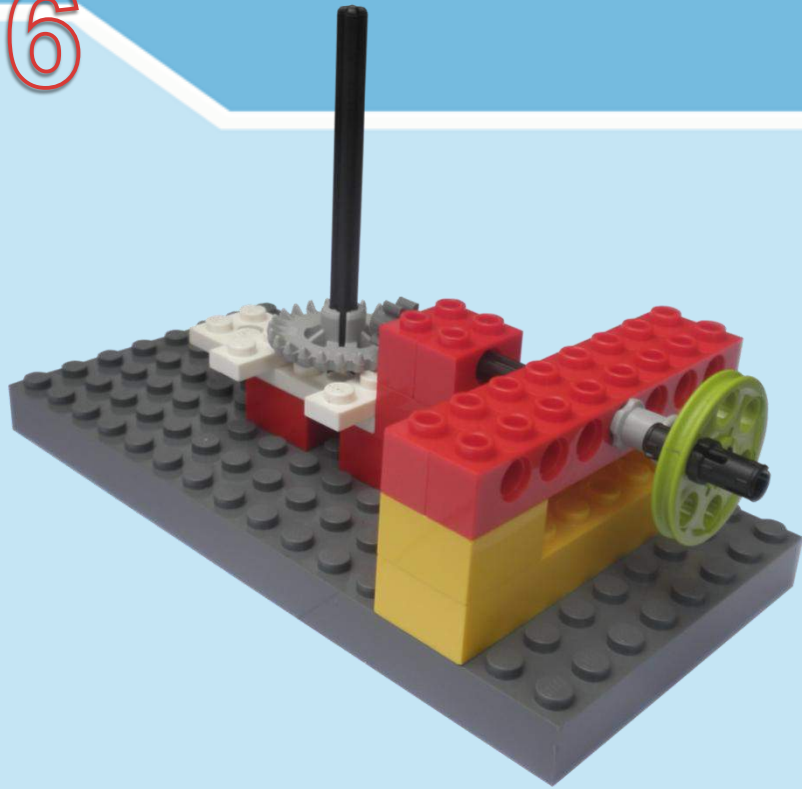

7

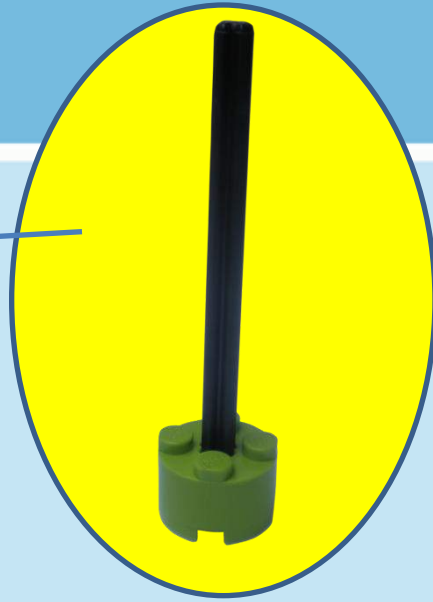
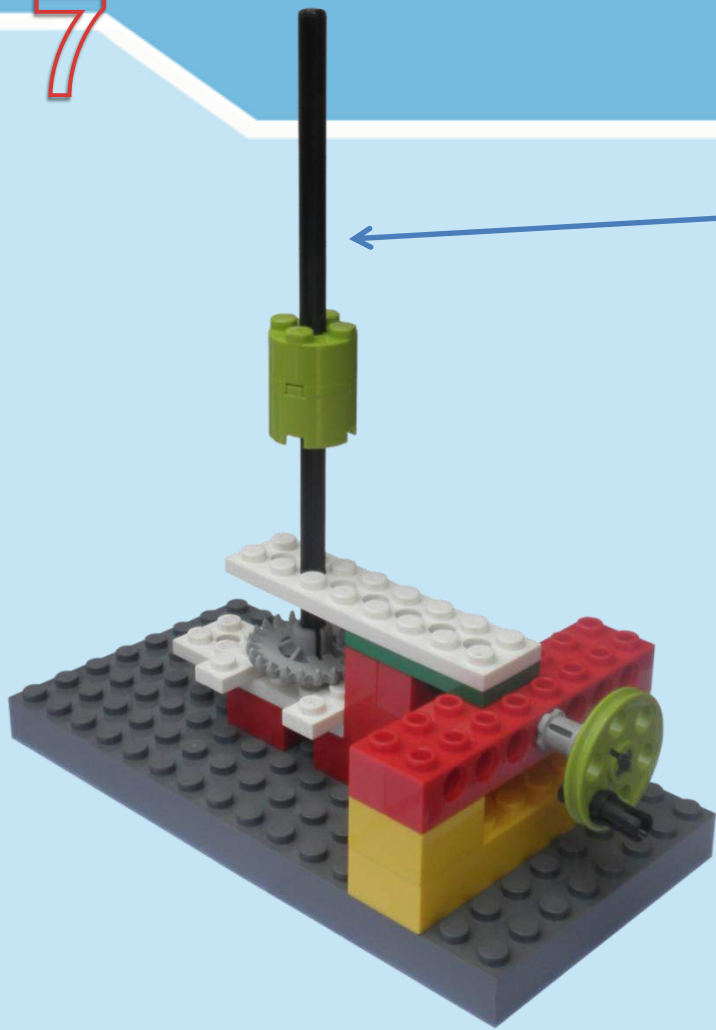

8



9

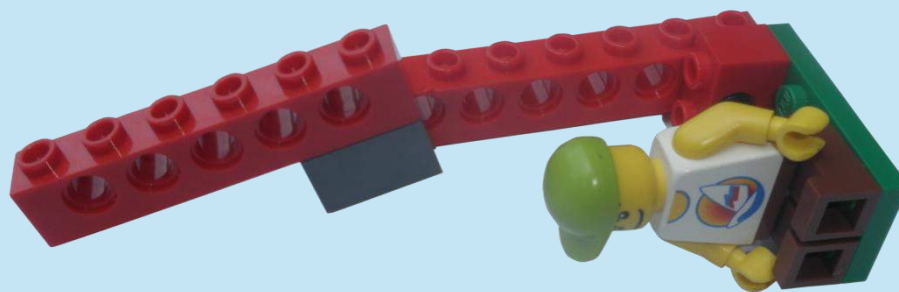
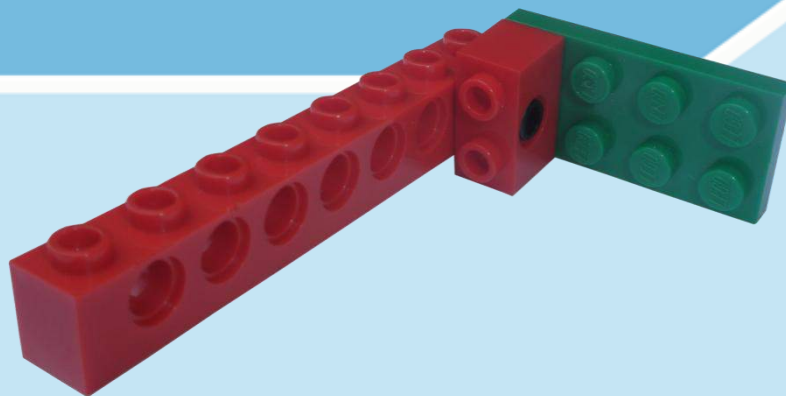
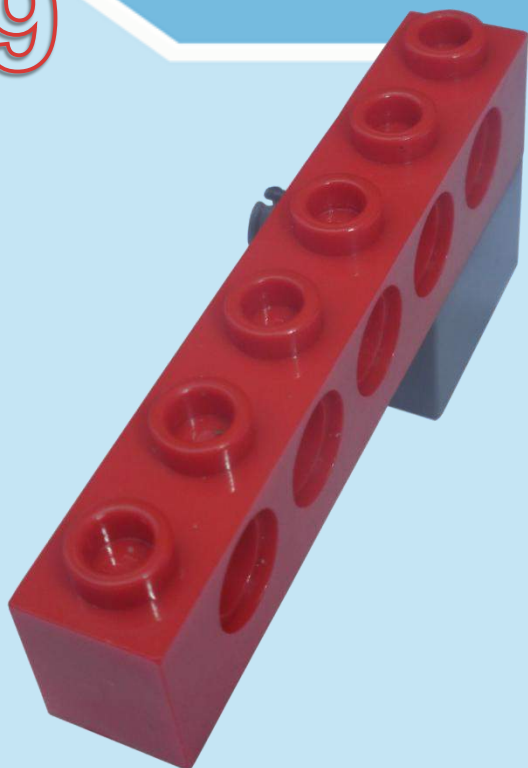

x2

10

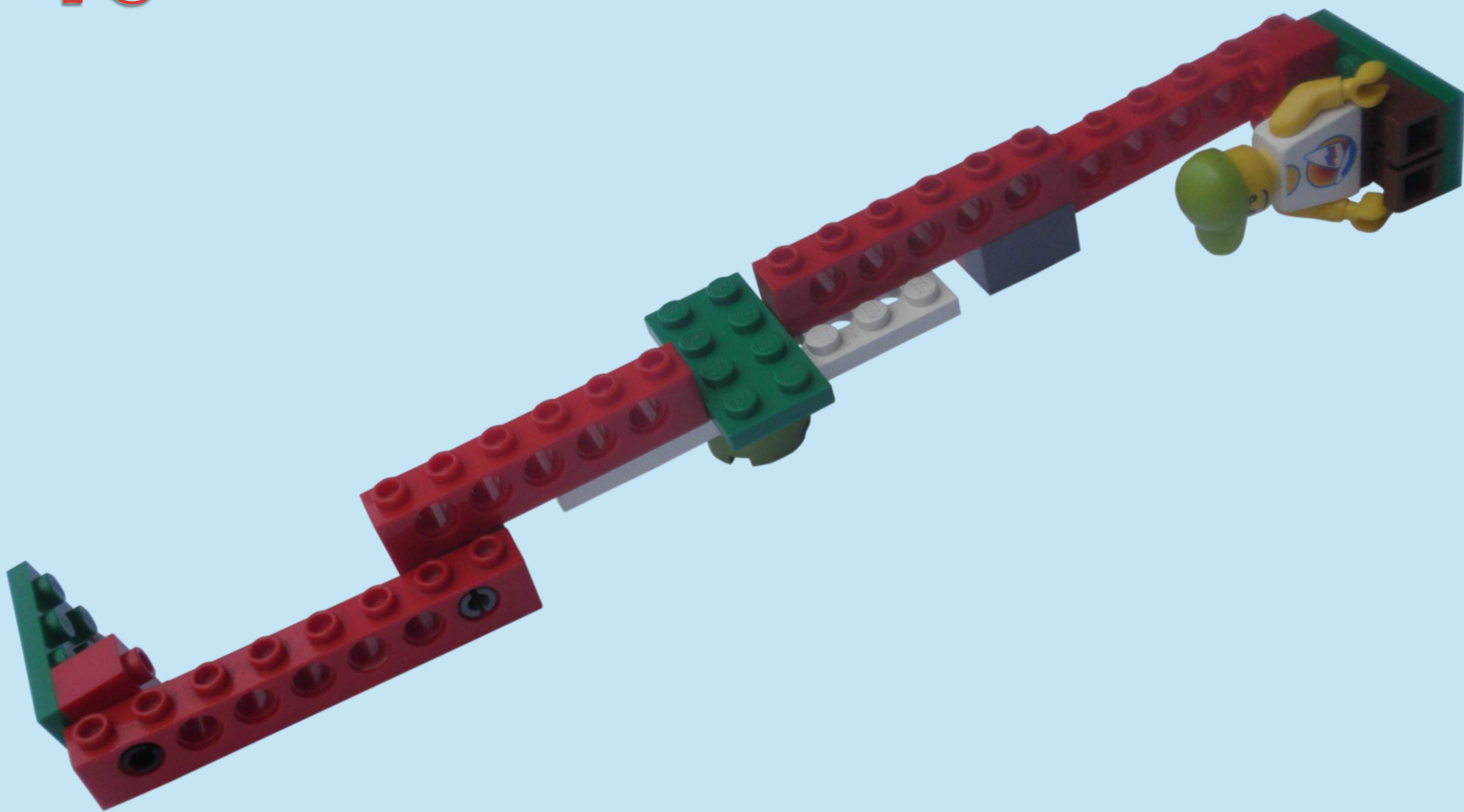

11



12

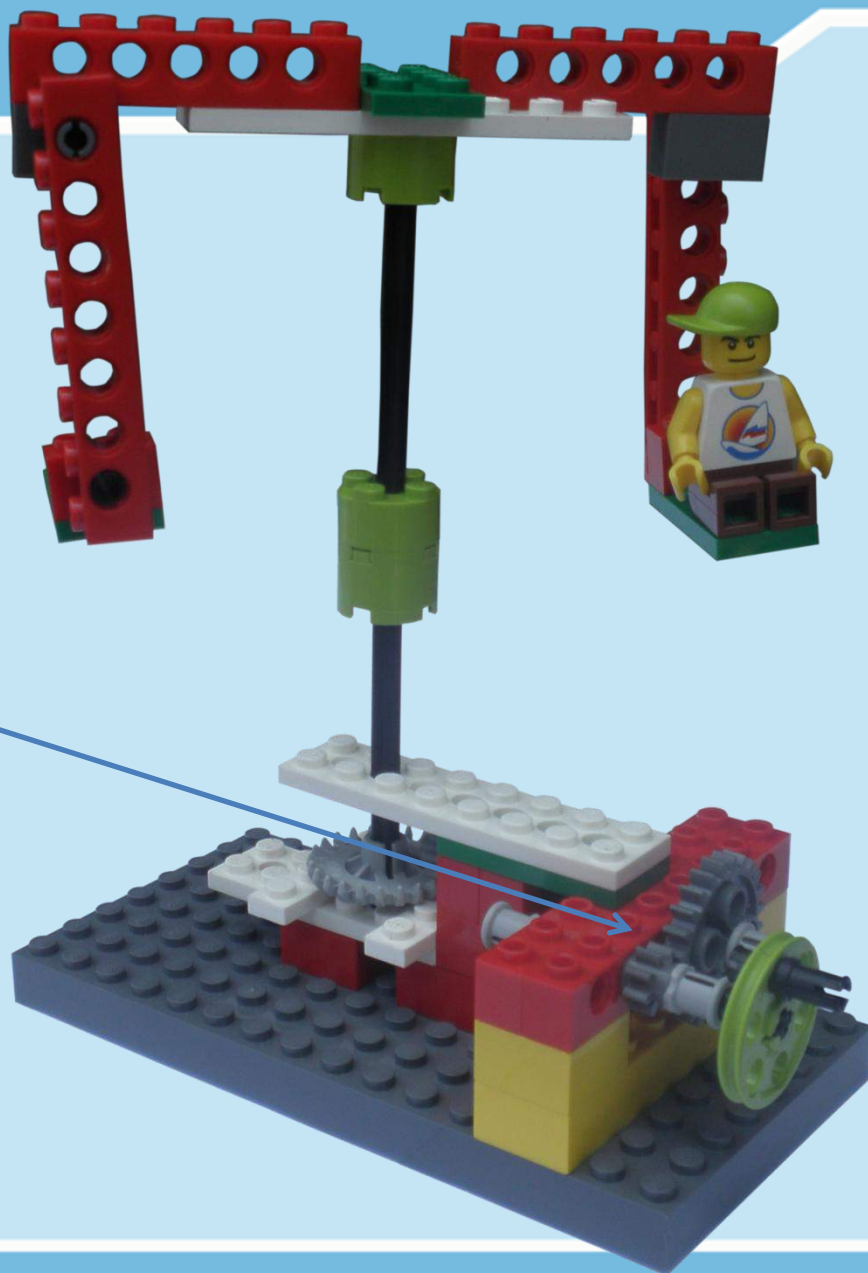
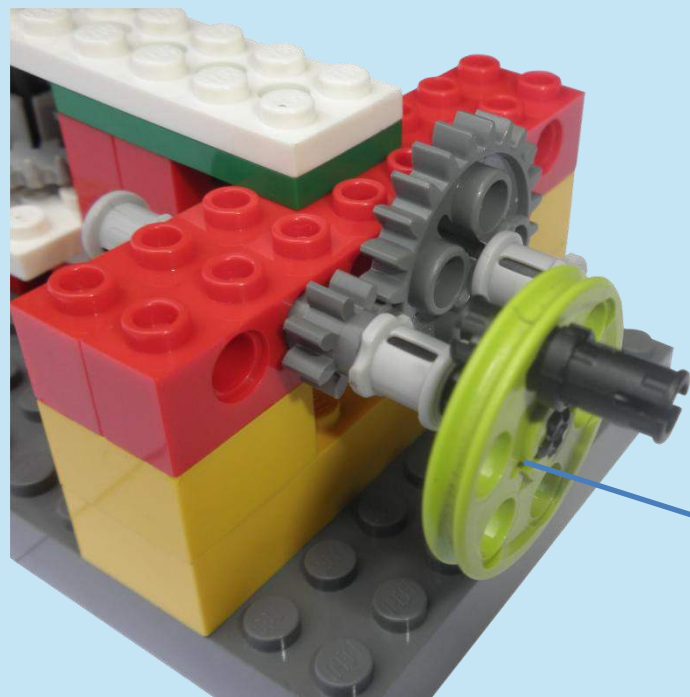

13

